

A stylized world map in shades of teal and green, serving as a background for the text.

Chengdu Ruisite Sports Goods Co., Ltd.

OxSynergy Core



GROUND BASE



COMBO DECLINE / GB-CD



COMBO INCLINE / GB-CI



COMBO TWIST / GB-CT



JAMMER / GB-J



SQUAT HIGH PULL
/ GB-SHP



SQUAT LUNGE / GB-SL



TWIST LEFT / GB-TL



TWIST RIGHT / GB-TR

GROUND BASE

PLATE-LOADED POWER BUILT FROM THE GROUND UP

Ground Base equipment is designed to keep the exerciser firmly planted on the ground, while maximizing balance and explosiveness from the feet up. Each of the eight different machines works several muscle groups at once.

The result is a total-body workout ideal for both sports specific and functional training.



ISO-LATERAL
BENCH PRESS / IL-BP



ISO-LATERAL
CHEST / BACK / IL-CB



ISO-LATERAL
D.Y. ROW / IL-DRW



ISO-LATERAL
DECLINE PRESS / IL-DCP



ISO-LATERAL FRONT LAT
PULLDOWN / IL-PD



ISO-LATERAL
HIGH ROW / IL-HR



ISO-LATERAL
HORIZONTAL PRESS
/ IL-HBP



ISO-LATERAL
INCLINE PRESS / IL-IP



ISO-LATERAL
LOW ROW / IL-LR



ISO-LATERAL
ROW / IL-ROW



ISO-LATERAL
SHOULDER PRESS / IL-SP



ISO-LATERAL SUPER
INCLINE PRESS / IL-FMP



ISO-LATERAL
WIDE CHEST / IL-WC



ISO-LATERAL WIDE
PULLDOWN / IL-WPD



ISO-LATERAL
LATERAL RAISE / PL-LR



4-WAY NECK / PL-4W



T-BAR ROW / PL-TBR



PULLOVER / PL-PO



SEATED BICEPS / PL-BI



SEATED DIP / PL-DIP



GLUTE DRIVE / PL-GLD



SEATED / STANDING
SHRUG / PL-SH

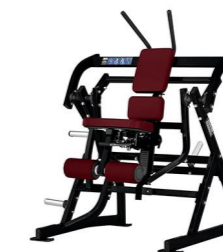

ABDOMINAL OBLIQUE
CRUNCH / PL-AB



GRIPPER / PL-GRIP

STRENGTH EQUIPMENT COLOR CHART

STRENGTH FRAME COLORS	Color Swatch	HD RACKS		
		NX & ID	HD ATHLETIC PRO BRIDGE AND RIG	
		NX Xmember are HW Charcoal Only	Upright & Xmember	
Platinum*		S	S	N/A
Black		S		N/A
Charcoal		S	S	N/A
Titanium*#		S	S	N/A
White		S	S	N/A
Blue		S	S	N/A
Red		S	S	N/A
Yellow		S	S	N/A
Midnight Metallic*		O	C	N/A
Mocha Sand		O	C	N/A
High Wear Charcoal		C	S	S
High Wear Platinum		C	S	S
Matte High WearTitanium		C	S	S
Matte High Wear White		C	S	S
Matte High WearYellow		C	S	S
Matte High Wear Red*		C	S	S
Matte High Wear Blue*		C	S	S
Custom		C	C	C

Key:
 S = Standard
 O = Optional
 C = Custom
 N/A = Not Available

Notes:

Hammer Strength Select and MTS have a second clear coat of paint
 ^ Colors do not match original High-Wear Red and High-Wear Blue
 New custom frame colors require a one-time Custom Formulation Set-Up fee

STRENGTH UPHOLSTERY COLORS	
American Beauty Red	Optional
Azure	Standard
Black	Standard
Black Carbon Fiber	Optional
Burgundy	Optional
Candy Apple Red	Standard
Chestnut	Optional
Cranberry	Standard
Dark Walnut	Standard
Dove Gray	Optional
Emerald Green	Optional
Graphite	Optional
Imperial Blue	Optional
Navy	Optional
Regimental Blue	Optional
Royal Blue	Standard
Slate	Standard
Suede	Optional
Terra Cotta	Optional
Wheat	Standard
Custom	Custom*

SELECT	CODE	DIMENSIONS (L xW x H)	WEIGHT
Pectoral Fly	HS-PEC	49" x 56" x 71" (125 cm x 143 cm x 181 cm)	580 lbs (264 kg)
Pectoral Fly/Rear Deltoid	HS-FLY	49" x 56" x 71" (125 cm x 143 cm x 181 cm)	580 lbs (264 kg)
Chest Press	HS-CP	41" x 57" x 64" (105 cm x 145 cm x 163 cm)	560 lbs (255 kg)
Shoulder Press	HS-SP	60" x 56" x 64" (153 cm x 143 cm x 163 cm)	520 lbs (236 kg)
Seated Row	HS-RW	52" x 34" x 71" (133 cm x 87 cm x 181 cm)	590 lbs (268 kg)
Lat Pulldown	HS-PD	54" x 33" x 89" (138 cm x 84 cm x 227 cm)	545 lbs (248 kg)
Fixed Pulldown	HS-FPD	58" x 55" x 73" (148 cm x 140 cm x 186 cm)	620 lbs (282 kg)
Biceps Curl	HS-BC	45" x 41" x 55" (115 cm x 105 cm x 140 cm)	450 lbs (205 kg)
Triceps Extension	HS-TE	45" x 44" x 55" (115 cm x 112 cm x 140 cm)	470 lbs (214 kg)
Lateral Raise	HS-LR	42" x 37" x 55" (107 cm x 94 cm x 140 cm)	535 lbs (243 kg)
Assist Dip Chin	HS-ADC	46" x 45" x 87" (117 cm x 115 cm x 221 cm)	655 lbs (298 kg)
Seated Leg Press	HS-SLP	79" x 40" x 71" (201 cm x 102 cm x 181 cm)	810 lbs (368 kg)
Leg Extension	HS-LE	47" x 41" x 64" (120 cm x 105 cm x 163 cm)	570 lbs (259 kg)
Leg Curl	HS-LC	65" x 39" x 55" (166 cm x 100 cm x 140 cm)	475 lbs (216 kg)
Seated Leg Curl	HS-SLC	55" x 34" x 55" (140 cm x 87 cm x 140 cm)	515 lbs (234 kg)
Horizontal Calf	HS-HC	61" x 32" x 55" (155 cm x 82 cm x 140 cm)	690 lbs (313 kg)
Hip Adduction	HS-HAD	61" x 26" x 55" (155 cm x 67 cm x 140 cm)	575 lbs (261 kg)
Hip Abduction	HS-HAB	61" x 26" x 55" (155 cm x 67 cm x 140 cm)	575 lbs (261 kg)
Back Extension	HS-BE	46" x 40" x 55" (117 cm x 102 cm x 140 cm)	560 lbs (255 kg)
Hip/Glute	HS-HG	65" x 39" x 72" (166 cm x 100 cm x 183 cm)	725 lbs (329 kg)
Abdominal Crunch	HS-ABC	62" x 35" x 56" (158 cm x 89 cm x 143 cm)	400 lbs (182 kg)
Standing Calf	HS-SC	58" x 45" x 71.5" (148 cm x 115 cm x 182 cm)	680 lbs (309 kg)

MTS	CODE	DIMENSIONS (L xW x H)	WEIGHT
Abdominal Crunch	MTSAB	44" x 39" x 56" (112 cm x 100 cm x 143 cm)	530 lbs (241 kg)
Iso-Lateral Biceps Curl	MTSBC	38" x 58" x 59" (97 cm x 148 cm x 150 cm)	520 lbs (236 kg)
Iso-LateralTriceps Extension	MTSTE	36" x 52" x 60" (92 cm x 133 cm x 153 cm)	580 lbs (264 kg)
Iso-Lateral Chest Press	MTSCP	40" x 68" x 77" (102 cm x 173 cm x 196 cm)	765 lbs (347 kg)
Iso-Lateral Incline Press	MTSIP	40" x 68" x 77" (102 cm x 173 cm x 196 cm)	765 lbs (347 kg)
Iso-Lateral Decline Press	MTSDP	39" x 64" x 66" (100 cm x 163 cm x 168 cm)	755 lbs (343 kg)
Iso-Lateral High Row	MTSHR	47" x 72" x 77" (120 cm x 183 cm x 196 cm)	780 lbs (354 kg)
Iso-Lateral Row	MTSRW	51" x 62" x 82" (130 cm x 158 cm x 209 cm)	765 lbs (347 kg)
Iso-Lateral Front Pulldown	MTSFP	48" x 58" x 80" (122 cm x 148 cm x 204 cm)	793 lbs (360 kg)
Iso-Lateral Shoulder Press	MTSSP	45" x 62" x 54" (115 cm x 158 cm x 138 cm)	746 lbs (339 kg)
Iso-Lateral Leg Extension	MTSLE	48" x 57" x 55" (122 cm x 145 cm x 140 cm)	750 lbs (341 kg)
Kneeling Leg Curl	MTSKC	45" x 62" x 54" (115 cm x 158 cm x 138 cm)	746 lbs (339 kg)

PLATE-LOADED	CODE	DIMENSIONS (L xW x H)	WEIGHT
Iso-Lateral Bench Press	IL-BP	49" x 52" x 69" (125 cm x 133 cm x 176 cm)	350 lbs (159 kg)
Iso-Lateral Horizontal Press	IL-HBP	66" x 61" x 42" (168 cm x 155 cm x 107 cm)	240 lbs (109 kg)
Iso-Lateral Super Incline Press	IL-FMP	50" x 59" x 60" (127 cm x 150 cm x 153 cm)	360 lbs (164 kg)
Iso-Lateral Incline Press	IL-IP	39" x 52" x 75" (100 cm x 133 cm x 191 cm)	325 lbs (148 kg)
Iso-Lateral Wide Chest	IL-WC	45" x 59" x 69" (115 cm x 150 cm x 176 cm)	305 lbs (139 kg)
Iso-Lateral Decline Press	IL-DCP	51" x 54" x 68" (130 cm x 138 cm x 173 cm)	315 lbs (143 kg)
Iso-Lateral Shoulder Press	IL-SP	51" x 58" x 74" (130 cm x 148 cm x 188 cm)	350 lbs (159 kg)
Iso-Lateral Chest/Back	IL-CB	72" x 52" x 82" (183 cm x 133 cm x 209 cm)	390 lbs (177 kg)
Iso-Lateral Front Lat Pulldown	IL-PD	65" x 41" x 80" (166 cm x 105 cm x 204 cm)	315 lbs (143 kg)
Iso-Lateral Wide Pulldown	IL-WPD	71" x 42" x 80" (181 cm x 107 cm x 204 cm)	320 lbs (146 kg)
Iso-Lateral High Row	IL-HR	61" x 41" x 79" (155 cm x 105 cm x 201 cm)	330 lbs (150 kg)
Iso-Lateral Rowing	IL-ROW	59" x 50" x 51" (150 cm x 127 cm x 130 cm)	280 lbs (128 kg)
Iso-Lateral D.Y. Row	IL-DRW	51" x 56" x 82" (130 cm x 143 cm x 209 cm)	360 lbs (164 kg)
Iso-Lateral Low Row	IL-LR	48" x 47" x 67" (122 cm x 120 cm x 171 cm)	335 lbs (152 kg)
Seated/Standing Shrug	PL-SH	42" x 60" x 49" (107 cm x 153 cm x 125 cm)	235 lbs (107 kg)
Seated Dip	PL-DIP	72" x 49" x 43" (182 cm x 124 cm x 109 cm)	285 lbs (130 kg)
Seated Biceps	PL-BI	50" x 46" x 53" (127 cm x 117 cm x 135 cm)	225 lbs (103 kg)
Iso-Lateral Lateral Raise	PL-LR	41" x 55" x 48" (105 cm x 140 cm x 122 cm)	295 lbs (134 kg)
Pullover	PL-PO	54" x 51" x 59" (138 cm x 130 cm x 150 cm)	370 lbs (168 kg)
4-Way Neck	PL-4W	33" x 54" x 62" (84 cm x 138 cm x 158 cm)	245 lbs (112 kg)
Gripper	PL-GRIP	50" x 28" x 47" (127 cm x 71 cm x 119 cm)	65 lbs (30 kg)
Abdominal Oblique Crunch	PL-AB	47" x 58" x 66" (120 cm x 148 cm x 168 cm)	355 lbs (162 kg)
Linear Leg Press	HSLLP	95" x 65" x 57" (242 cm x 166 cm x 145 cm)	630 lbs (286 kg)
Hack Squat	PL-HSQ	85" x 61" x 59" (216 cm x 155 cm x 153 cm)	504 lbs (229 kg)
Leg Press	PL-LP	69" x 51" x 57" (176 cm x 130 cm x 145 cm)	535 lbs (243 kg)
Iso-Lateral Leg Press	IL-LP	70" x 59.5" x 60" (178 cm x 152 cm x 153 cm)	605 lbs (275 kg)
V-Squat	PL-VSQ	97" x 42" x 81" (247 cm x 107 cm x 205 cm)	530 lbs (241 kg)
Seated Calf Raise	PL-CALF	49" x 33" x 54" (124 cm x 84 cm x 137 cm)	200 lbs (91 kg)
Super Horizontal Calf	PL-SHC	64" x 57" x 60" (163 cm x 145 cm x 152 cm)	380 lbs (173 kg)
Assisted Nordic Hamstring	PL-ANH	77" x 53" x 58" (196 cm x 135 cm x 147 cm)	400 lbs (181 kg)
Leg Extension	PL-LE	56" x 54" x 57" (143 cm x 138 cm x 145 cm)	295 lbs (134 kg)

PLATE-LOADED	CODE	DIMENSIONS (L xW x H)	WEIGHT
Iso-Lateral Kneeling Leg Curl	IL-KLC	43" x 50" x 47" (110 cm x 127 cm x 120 cm)	250 lbs (114 kg)
Seated Leg Curl	PL-SLC	53" x 54" x 49" (135 cm x 138 cm x 125 cm)	330 lbs (150 kg)
Iso-Lateral Leg Extension	IL-LE	54" x 57" x 57" (138 cm x 145 cm x 145 cm)	300 lbs (137 kg)
Iso-Lateral Leg Curl	IL-LC	71" x 53" x 39" (181 cm x 135 cm x 100 cm)	285 lbs (130 kg)
Tibia Dorsi Flexion	PL-TIB	15" x 24" x 12" (39 cm x 61 cm x 31 cm)	52 lbs (24 kg)
Vertical Smith Machine	HSSMV	50" x 90" x 93" (127 cm x 229 cm x 236 cm)	571 lbs (259 kg)
T-Bar Row	PL-TBR	82" x 33" x 21" (210 cm x 82 cm x 53 cm)	200 lbs (90.7 kg)
Glute Drive	PL-GLD	68" x 59" x 40" (173cm x 149cm x 102cm)	318 lbs (144 kg)
Glute Ham/Reverse Hyper Combo	PL-GHRH	88" x 40" x 53" (224 cm x 102 cm x 135 cm)	337 lbs (153 kg)
Belt Squat	PL-BSQ	78" x 63" x 64" (198cm x 160cm x 132cm)	485 lbs (220 kg) with Dip Attachment

GROUND BASE	CODE	DIMENSIONS (L xW x H)	WEIGHT
Jammer	GB-J	59" x 66" x 90" (150 cm x 168 cm x 229 cm)	370 lbs (168 kg)
Combo Incline	GB-CI	58" x 58" x 55" (148 cm x 148 cm x 140 cm)	275 lbs (125 kg)
Combo Decline	GB-CD	65" x 51" x 96" (166 cm x 130 cm x 244 cm)	360 lbs (164 kg)
ComboTwist	GB-CT	58" x 58" x 55" (148 cm x 148 cm x 140 cm)	275 lbs (125 kg)
Twist Right	GB-TR	55" x 50" x 55" (140 cm x 127 cm x 140 cm)	200 lbs (91 kg)
Twist Left	GB-TL	55" x 50" x 55" (140 cm x 127 cm x 140 cm)	200 lbs (91 kg)
Squat Lunge	GB-SL	54" x 54" x 32" (138 cm x 138 cm x 82 cm)	240 lbs (109 kg)
Squat High Pull	GB-SHP	62" x 57" x 34" (158 cm x 145 cm x 87 cm)	220 lbs (100 kg)

BENCHES AND STORAGE	CODE	DIMENSIONS (L xW x H)	WEIGHT
Olympic Bench Weight Storage	O-BWS	22" x 15" x 46" (56 cm x 39 cm x 117 cm)	62 lbs (29 kg)
Olympic Military Bench	O-MB	56" x 48" x 65" (143 cm x 122 cm x 166 cm)	339 lbs (154 kg)
Olympic Flat Bench	O-FB	52" x 50" x 50" (133 cm x 127 cm x 127 cm)	145 lbs (66 kg)
Olympic Incline Bench	OIB	51" x 52" x 58" (130 cm x 133 cm x 148 cm)	198 lbs (90 kg)
Olympic Squat Rack	OSR	59" x 69" x 73" (150 cm x 176 cm x 186 cm)	290 lbs (132 kg)
Olympic Decline Bench	O-DB	60" x 53" x 50" (153 cm x 135 cm x 127 cm)	190 lbs (87 kg)
Adjustable Bench (Pro Style)	FWMAB	55" x 26" x 17" (140 cm x 67 cm x 44 cm)	115 lbs (53 kg)
Flat Bench	FW-FB	50" x 22" x 16" (127 cm x 56 cm x 41 cm)	54 lbs (25 kg)
Decline/Abdominal Bench	FW-DB	63" x 24" x 34" (161 cm x 61 cm x 87 cm)	100 lbs (46 kg)
Utility Bench - 75-degree	FW-UB75	51" x 25" x 37" (130 cm x 64 cm x 94 cm)	65 lbs (30 kg)
Smith Machine	HSSM	50" x 86.5" x 93" (127 cm x 220 cm x 237 cm)	635 lbs (289 kg)
Seated Arm Curl	FW-AC	39" x 36" x 43" (100 cm x 92 cm x 110 cm)	160 lbs (73 kg)
Single-Tier Dumbbell Rack	FW-DR1	90" x 16.5" x 24" (229 cm x 42 cm x 61 cm)	93 lbs (43 kg)
Two-Tier Dumbbell Rack	FW-DR2	90" x 24" x 32" (229 cm x 61 cm x 82 cm)	155 lbs (71 kg)
Barbell Rack	FW-BAR	31" x 28" x 60" (79 cm x 72 cm x 153 cm)	142 lbs (65 kg)
Deluxe WeightTree	FW-DWT	20" x 27" x 39" (51 cm x 69 cm x 100 cm)	73 lbs (34 kg)
Small Bumper Plate Storage	FW-BPS	46" x 16" x 11.5" (117 cm x 41 cm x 30 cm)	44 lbs (20 kg)
Large Bumper Plate Storage	FW-BPL	72" x 16" x 12" (183 cm x 41 cm x 31 cm)	88 lbs (40 kg)
Back Extension	BW-BE	59" x 28" x 43" (150 cm x 72 cm x 110 cm)	135 lbs (62 kg)
Chin/Dip/Leg Raise	BW-CDL	48" x 42" x 92" (122 cm x 107 cm x 234 cm)	250 lbs (114 kg)
Glute/Ham	BW-GH	72" x 33" x 50" (183 cm x 84 cm x 127 cm)	329 lbs (150 kg)
Fixed Pad Glute/Ham	BW-GHF	72" x 32" x 50" (183 cm x 82 cm x 127 cm)	329 lbs (150 kg)
HD Athletic Multi-Adjustable Bench	HDT-MAB	52" x 22" x 18.5" (133 cm x 56 cm x 47 cm)	85 lbs (39 kg)

PLATFORMS	CODE	DIMENSIONS (L xW x H)	WEIGHT
Impact Suppression	ISP-4X8	51.5" x 94.5" x 3.25" (131 cm x 240 cm x 8.3 cm)	316 lb (143 kg)
Impact Suppression	ISP-6X8	75.5" x 94.5" x 3.25" (131 cm x 240 cm x 8.3 cm)	408 lb (185 kg)
Traditional Wood	TWP-4X8	51.5" x 94.5" x 3.25" (131 cm x 240 cm x 8.3 cm)	316 lb (143 kg)
Traditional Wood	TWP-6X8	75.5" x 94.5" x 3.25" (131 cm x 240 cm x 8.3 cm)	408 lb (185 kg)
Rubber	RPI-4X8	48" x 92" x 0.75" (122 cm x 234 cm 1.9 cm)	120 lb (54 kg)
Rubber	RPI-6X8	72" x 92" x 0.75" (183 cm x 234 cm 1.9 cm)	130 lb (59 kg)

HD ATHLETIC ACCESSORIES						
42" Xmembers	HALF RACK AND COMBO RACK	POWER RACK	RACK CONNECTORS	RIGS	PERIMETER	BRIDGE
42" Monkey Bar	–	Front Only	–	•	•	•
42" Straight Bar	–	Front Only	–	•	–	–
42" Thick Skinny	Rear Only	Front or Rear	–	•	Front Only	–
42" Multi-Grip Bar	Rear Only	Rear Only	–	•	–	–
42" Off Set	–	Front Only	–	•	Front Only	–
42" Suspension Chin	–	–	–	–	Front Only	–
42" Square	–	Front Only	–	•	•	–
72" Xmembers / 72" Xmember Connectors						
72" Monkey Bar	–	–	•	•	•	•
72" Straight Bar	–	–	•	•	Front Only	–
72" Thick Skinny	–	–	•	•	Front Only	–
72" Off Set	–	–	•	•	Front Only	–
72" Suspension Chin	–	–	–	–	Front Only	–
72" Square	–	–	•	•	•	•
Square Xmember Accessories*						
3" Ball Grip* (Pair)	•	•	•	•	•	•
Neutral Grip Handles* (Pair)	•	•	•	•	•	•
Arc Bar*	•	•	•	•	•	•
Bar Supports & Catches						
Bar Support (Pair)	S	S	N/A	•	•	•
Half Rack Bar Catch (Pair)	S	–	N/A	•	•	•
Power Rack Bar Catch (Pair)	–	S	N/A	–	–	–
Flexible Bar Catch (Pair)	–	•	N/A	•	•	•
Misc. Accessories						
Band Pegs (Pair)	•	•	N/A	•	•	•
Dip Handles	•	•	N/A	•	•	•
Power Pivot	•	•	N/A	•	•	•
Rig Bar Storage	–	–	N/A	•	•	•
Rack Bumper Plate Storage	•	•	N/A	–	–	–
Weight Horns	S	S	N/A	•	•	S
Wing 42"	•	•	N/A	•	•	–
Wing 72"	–	–	•	•	•	–
Bumper Plate Divider	•	•	•	•	•	•
Wall BallTarget	•	•	N/A	•	•	•
Heavy Bag Hanger	•	•	N/A	•	•	•
Storage Components						
42" 2 Pipe	–	–	–	•	•	–
42" Kettlebell Tray	–	–	–	•	•	–
42" Dumbbell Tray	–	–	–	•	•	–
42" Stability Ball Storage	–	–	–	•	•	•
72" 2 Pipe	–	–	•	•	•	•
72" Kettlebell Tray	–	–	•	•	•	•
72" DumbbellTray	–	–	•	•	•	•
72" Stability Ball Storage	–	–	•	•	•	•



MTS



ABDOMINAL CRUNCH
/ MTSAB



**ISO-LATERAL
BICEPS CURL** / MTSBC



**ISO-LATERAL
CHEST PRESS** / MTSCP



**ISO-LATERAL
LEG EXTENSION** / MTSLE



**ISO-LATERAL KNEELING
LEG CURL** / MTSKC



**ISO-LATERAL FRONT
PULLDOWN** / MTSFP



**ISO-LATERAL
DECLINE PRESS** / MTSDP



**ISO-LATERAL
SHOULDER PRESS** / MTSSP



**ISO-LATERAL TRICEPS
EXTENSION** / MTSTE



ISO-LATERAL HIGH ROW
/ MTSHR



**ISO-LATERAL INCLINE
PRESS** / MTSIP



ISO-LATERAL ROW
/ MTSRW



ASSIST DIP CHIN / HS-ADC



BICEPS CURL / HS-BC



CHEST PRESS / HS-CP



FIXED PULLDOWN / HS-FPD



LAT PULLDOWN / HS-PD



LATERAL RAISE / HS-LR



PECTORAL FLY / HS-PEC



PECTORAL FLY / REAR DELTOID / HS-FLY



SEATED ROW / HS-RW



SHOULDER PRESS / HS-SP



TRICEPS EXTENSION / HS-TE



HIP ABDUCTION / HS-HAB



HIP ADDUCTION / HS-HAD



HIP / GLUTE / HS-HG



HORIZONTAL CALF / HS-HC



LEG CURL / HS-LC



LEG EXTENSION / HS-LE



SEATED LEG CURL / HS-SLC



SEATED LEG PRESS / HS-SLP



STANDING CALF / HS-SC



ABDOMINAL CRUNCH / HS-ABC



BACK EXTENSION / HS-BE



型号: LY-YG001
 名称: 推胸训练器 Wide Chest Press
 规格: 1465 × 1775 × 1905
 净重: 238

- 1.推胸训练器可以有效地提高胸部肌肉, 通过不同的把位可以锻炼胸肌的多个部位
- 2.采用3.5mm管材
- 3.顺畅的运动轨迹更符合人体工学原理
4. 多方位调节器
5. 坐垫表面采用进口PU, 防水耐磨, 多色可选
6. 漆面多种颜色可选

- 1.Push-up training equipment can effectively enhance chest muscles, and through different grips, it can exercise various parts of the pectoral muscles
- 2.Using 3.5mm tubing
- 3.Smooth exercise trajectory is more in line with ergonomic principles
- 4.Multi-adjustable regulator
- 5.The seat surface is made of imported PU, which is waterproof and wear-resistant, available in multiple colors
- 6.Multiple colors available for the lacquered surface



型号: LY-YG005
 名称: 剪刀拉背
 Wide Pulldown Rear
 规格: 1270 × 1660 × 2040
 净重: 238



型号: LY-YG006
 名称: 剪刀拉背
 Wide Pulldown Rear
 规格: 1310x2010x2110
 净重: 268



型号: LY-YG007
 名称: 分动式下拉训练器
 Front Row
 规格: 1430 × 1880 × 1855
 净重: 175



型号: LY-YG008
 名称: 坐姿划船
 Seated Row
 规格: 1330 × 1490 × 1405
 净重: 150



型号: LY-YG009
 名称: 低拉划船
 LOW ROW
 规格: 1515 × 1545 × 1550
 净重: 210



型号: LY-YG010
 名称: 多功能划船器
 Bentover Row
 规格: 1240x2165x1465
 净重: 210



型号: LY-YG002
 名称: 上斜推胸
 Incline Chest Press
 规格: 1680 × 1825 × 1410
 净重: 268



型号: LY-YG003
 名称: 下斜推胸
 Chest&Decline Combo
 规格: 1635 × 1675 × 1410
 净重: 220



型号: LY-YG004
 名称: 坐姿夹胸训练器
 Pec Dec Fly
 规格: 1450 × 1760 × 1410
 净重: 150



型号: LY-YG011
 名称: 坐姿推肩
 Shoulder Press
 规格: 1700 × 1890 × 1315
 净重: 238



型号: LY-YG012
 名称: 坐姿侧平举
 Lateral Raise
 规格: 1425 × 1140 × 1380
 净重: 158



型号: LY-YG013
 名称: 过顶臂屈伸
 Overhead Extension
 规格: 1350 × 1300 × 1400
 净重: 150



型号: LY-YG014
名称: 坐姿伸腿
Leg Extension
规格: 1430 × 1600 × 1090
净重: 230



型号: LY-YG015
名称: 俯身腿弯举
Leg Curl
规格: 1790x1330x830
净重: 180



型号: LY-YG016
名称: 臀后蹬腿
Glute Ham
规格: 1300x1570x1730
净重: 139



型号: LY-YG023
名称: 水平罗马椅GHD 90°
Roman Chair
规格: 920x1400x1130
净重: 64



型号: LY-YG024
名称: 直角凳
Utility Bench
规格: 700x1330x880
净重: 25.5



型号: LY-YG025
名称: 单举式平板卧推床
Olympic Bench
规格: 1530x1720x1155
净重: 96



型号: LY-YG017
名称: V字深蹲
V-Squat
规格: 1520 × 2155 × 1570
净重: 268



型号: LY-YG018
名称: 哈克斜蹲
Hack Squat
规格: 1500 × 2290 × 1490
净重: 240



型号: LY-YG019
名称: 倒蹬机
Power Leg Press
规格: 1520 × 2170 × 1295
净重: 240



型号: LY-YG026
名称: 腹肌凳 Sit Up
规格: 690x1520x1120
净重: 38



型号: LY-YG027
名称: 站姿牧师凳
Preacher Curl Bench
规格: 800x1020x940
净重: 40



型号: LY-YG028
名称: 可调训练凳
Adjust Incline Bench
规格: 610x1520x500
净重: 46



型号: LY-YG020
名称: 臀桥机
Hip Thrust
规格: 1400 × 1850 × 1055
净重: 110



型号: LY-YG021
名称: 俯身反向飞鸟
Bentover Lateral Raise
规格: 745x1760x965
净重: 85



型号: LY-YG022
名称: T杠划船器
T-Bar Row
规格: 900x2167x895
净重: 75



型号: LY-YG029
名称: 双杠臂屈伸 提膝腹肌训练架
Dip & Leg Raise
规格: 700x1440x1580
净重: 75



型号: LY-YG030
名称: 牧师凳
Preacher Curl Bench
规格: 840x1075x960
净重: 42



型号: LY-YG031
名称: 平凳 Flat Bench
规格: 680x1300x435
净重: 27.5



Perform a horizontal leg kick while hanging.

产品尺寸 (SIZE) : 2350L*1730W*1200H



Seated dynamic back stretch

产品尺寸 (SIZE) : 2200L*1100W*900H



Split cable bicep trainer

产品尺寸 (SIZE) 1400*1500*1390



Seated chest press

产品尺寸 (SIZE) : 1500*1100*1800



Seated shoulder press

产品尺寸 (SIZE) 1300L*1150W*1400H



Slide horizontally into the middle of the chest

产品尺寸 (SIZE) : 1400L*1200W*1750H

配重重量 : 103KG



Double-position high pull trainer

产品尺寸 (SIZE) : 1620L*760W*2250H

配重重量 : 105KG



The first generation of chain clause prone leg hook

产品尺寸 (SIZE) : 2300*510*1350

配重重量 : 75KG

◀◀ N系列



2031

First-generation chain clause sitting leg kick

产品尺寸 (SIZE) : 1380Lx820Wx1530H

配重重量 : 100



2033

A straight-arm press machine for chain links

产品尺寸 (SIZE) : 1100Lx1150Wx1450H

配重重量 : 100KG



2036

Chain-link nautilus, straight-arm press

产品尺寸 (SIZE) : 980L*1050W*500H

配重重量 : 100KG



2037

Chest triangle chain clamp, rear deltoid machine (40 degrees)

产品尺寸 (SIZE) : 980L*1050W*1500H

配重重量 : 100KG



Chain lateral raise and shoulder press machine

产品尺寸 (SIZE) : 1380Lx820Wx1530H

配重重量 : 138KG



Chain Armored Nautilus (Ladies' Version)

产品尺寸 (SIZE) : 1380Lx820Wx1530H

配重重量 : 100KG



Seated calf raises

产品尺寸 (SIZE) : 1380Lx820Wx1530H



ZERO SHORTCUTS ALL GAINS

编号Number: CXN-2002

尺寸size: 180L*150W* 147Hcm

重量weight: 218KG



PRODUCT CUSTOMIZATION

编号Number: CXN-2003

尺寸size: 193L*130W* 130Hcm

重量weight: 218KG



CHEST PRESS

编号Number: CXN-2004

尺寸size: 206L* 147W * 124Hcm

重量weight: 228KG



LAT PULL DOWN

编号Number: CXN-3003

尺寸size: 206L* 130W*2203Hcm

重量weight:184KG



LOW ROW

编号Number: CXN-3004

尺寸size: 210L* 130W* 117Hcm

重量weight:193KG



Deadlift shrug trainer

编号Number: CXN-3004

尺寸size: 188L* 156W*79Hcm

重量weight:113KG



DECLINE PRESS

编号Number: CXN-4002

尺寸size: 180L* 130W* 147Hcm

重量weight:186KG



BICEPS CURL

编号Number: CXN-5002

尺寸size:155L* 157W* 104Hcm

重量weight:211KG



ABDOMINAL CRUNCH

编号Number: CXN-5003

尺寸size:157L* 156W* 156Hcm

重量weight:209KG



45-degree leg extension machine

编号Number: CXN-1141

尺寸size: 229L* 182W* 147Hcm

重量weight:258KG



High row training machine

编号Number: CXN-3005

尺寸size: 218L* 130W* 185Hcm

重量weight:201KG



Hack squat machine

编号Number: CXN-1130

尺寸size: 236L* 182W* 119Hcm

重量weight:220KG



▶ LDAS-111 ◀

Vertical Row
垂直划船训练器
L/长: 1750mm W/宽: 1320mm
H/高: 1320mm WEIGHT/重量: 127kg



▶ LDAS-115 ◀

Standing Viking Shoulder Press
站姿举肩训练器
L/长: 1420mm W/宽: 1270mm
H/高: 1900mm WEIGHT/重量: 166kg



▶ LDAS-125 ◀

Incline Fly
飞鸟训练器
L/长: 1630mm W/宽: 990mm
H/高: 760mm WEIGHT/重量: 87kg



▶ LDAS-126 ◀

Hip Thrust
臀桥训练器
L/长: 1800mm W/宽: 1830mm
H/高: 915mm WEIGHT/重量: 115kg



▶ LDAS-119 ◀

Leg Extension
坐式伸腿训练器
L/长: 1220mm W/宽: 1400mm
H/高: 1140mm WEIGHT/重量: 195kg



▶ LDAS-121 ◀

Rowing Machine
T型划船训练器
L/长: 1750mm W/宽: 1170mm
H/高: 590mm WEIGHT/重量: 110kg



▶ LDAS-131 ◀

Standing Deadlift
可调硬拉训练器
L/长: 1665mm W/宽: 1780mm
H/高: 745mm WEIGHT/重量: 138kg



▶ LDAS-138 ◀

Kettlebell Squat Trainer
钟摆深蹲训练器
L/长: 2450mm W/宽: 1420mm
H/高: 2080mm WEIGHT/重量: 320kg



▶ LDAS-122 ◀

Seated Triceps Press
三头下压训练器
L/长: 1100mm W/宽: 690mm
H/高: 1180mm WEIGHT/重量: 90kg



▶ LDAS-123 ◀

Abdominal Isolator
后链肌训练器
L/长: 1700mm W/宽: 1300mm
H/高: 1855mm WEIGHT/重量: 190kg



▶ LDAS-201 ◀

Standing Calf
坐式小腿训练器
L/长: 1525mm W/宽: 820mm
H/高: 915mm WEIGHT/重量: 70kg



▶ LDAS-202 ◀

Prone Rowing
俯身拉背训练器
L/长: 1815mm W/宽: 930mm
H/高: 1335mm WEIGHT/重量: 215kg



▶ LDAS-101 ◀

Multi Row
多把位划船训练器

L/长: 1570mm W/宽: 1180mm
H/高: 1660mm WEIGHT/重量: 185kg



▶ LDAS-038 ◀

Shoulder Press Bench
推肩凳

L/长: 1370mm W/宽: 1050mm
H/高: 700mm WEIGHT/重量: 65kg



▶ LDAS-042 ◀

Incline Chest Press
上斜推胸训练器

L/长: 1700mm W/宽: 1370mm
H/高: 1200mm WEIGHT/重量: 132kg



▶ LDAS-051 ◀

Seated Shoulder Press
肩部推举训练器

L/长: 1300mm W/宽: 1170mm
H/高: 1200mm WEIGHT/重量: 132kg



▶ LDAS-108 ◀

High Pulley
高位下拉训练器

L/长: 1680mm W/宽: 1220mm
H/高: 2200mm WEIGHT/重量: 125kg



▶ LDAS-110 ◀

Flat Bench Chest Press
平卧推胸训练器

L/长: 1510mm W/宽: 1370mm
H/高: 1040mm WEIGHT/重量: 123kg

SF90



坐姿推胸训练器 Chest Press

SF90 001



产品尺寸 (mm) : 1090*1420*1500



直臂夹胸训练器 Pec Fly / Rear Delt

产品型号	SF90 002A
产品尺寸 (mm)	1210*1570*2060



蝴蝶机训练器 Pec Fly

产品型号	SF90 002
产品尺寸 (mm)	1100*1260*1500



推肩训练器 Delts Machine

产品型号	SF90 003A
产品尺寸 (mm)	1320*1340*1500



坐姿划船训练器 Seated Row

产品型号	SF90 004
产品尺寸 (mm)	1370*1320*1500



肩部推举训练器 Shoulder Press

产品型号	SF90 003
产品尺寸 (mm)	1650*1520*1500



二头肌训练器 Biceps Curl

产品型号	SF90 006
产品尺寸 (mm)	1180*1550*1500



三头肌训练器 Triceps Press

产品型号	SF90 007
产品尺寸 (mm)	1340*1030*1500

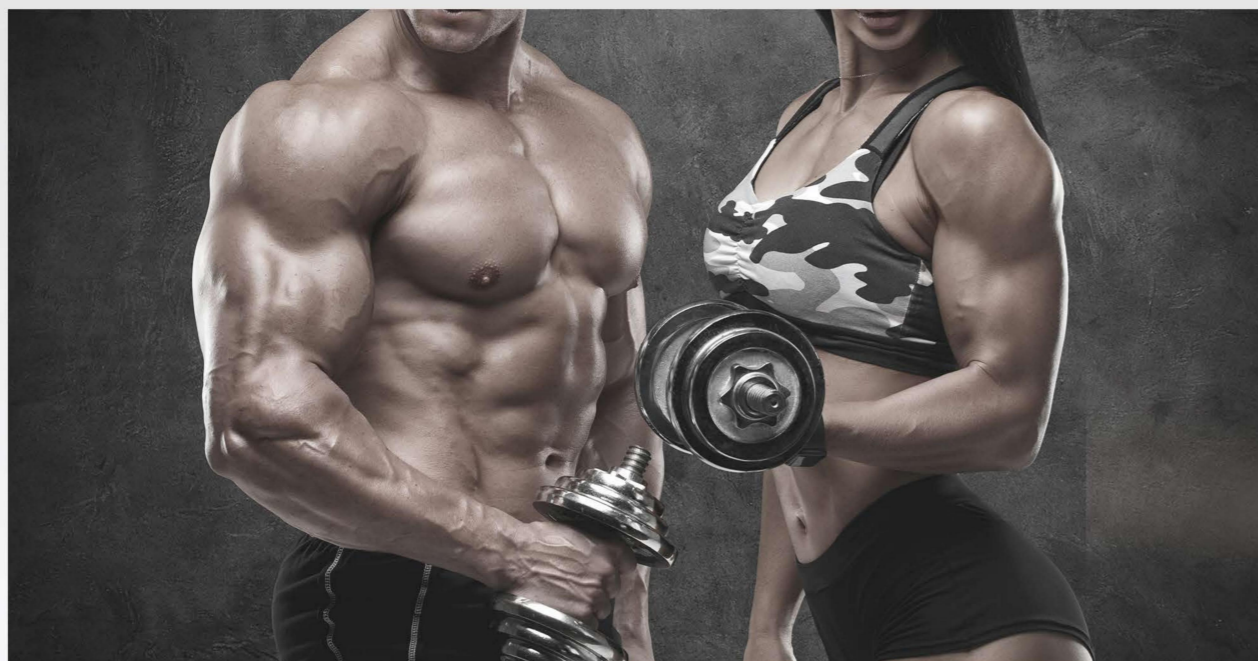

腹部前屈训练器 Abdominal Crunch

产品型号	SF90 010
产品尺寸 (mm)	1240*1230*1500



旋转训练器 Rotary Torso

产品型号	SF90 011
产品尺寸 (mm)	1280*1240*1580



上肢屈伸训练器 Assisted Chin/Dip

产品型号	SF90 008
产品尺寸 (mm)	1650*1650*2250

背肌训练器 Lower Back

产品型号	SF90 009
产品尺寸 (mm)	1450*1070*1500



高拉背训练器 lat pull down

产品型号	SF90 012
产品尺寸 (mm)	1380*1360*2000



坐式屈腿训练器 Seated Leg Curl

产品型号	SF90 013
产品尺寸 (mm)	1450*1010*1500



伸腿训练器 Leg Extension

产品型号	SF90 014
产品尺寸 (mm)	1420*1070*1500



大腿伸展训练器 Standing Leg Extension

产品型号	SF90 016A
产品尺寸 (mm)	1870*970*1500



坐姿小腿训练器 Calf Extension

产品型号	SF90 017
产品尺寸 (mm)	1690*1060*1500



卧式屈腿训练器 Horizontal Leg Curl

产品型号	SF90 013A
产品尺寸 (mm)	1450*1020*1500



腿部推蹬训练器 Leg Press

产品型号	SF90 015
产品尺寸 (mm)	2000*1220*1500



腿部内弯训练器 Adductor

产品型号	SF90 018
产品尺寸 (mm)	810*1830*1500



腿部外弯训练器 Abductor

产品型号	SF90 019
产品尺寸 (mm)	810*1830*1500



TS-001

seated chest press machine

- The overall design is steady and heavy, with smooth lines and unique recognition;
- Unique button spring cushioning structure; The handle is anti slip and sweat wicking, providing a comfortable grip;
- Simulate the natural movement trajectory of the human body, providing a smooth training experience;

Standard counterweight: 100KG
size: 1080*1450*1600



TS-003

Shoulder press trainer

- Absorb international cutting-edge sports mechanics technology, balance force ratio, and use uniform force throughout the entire process;
- The balanced rubber hammer is sufficient to balance the excess gravity at the beginning of the movement, and the counterweight matches accurately;
- The design of the movable pulley box is simple and elegant, with finely polished guide rods and smooth use;

Standard counterweight: 60KG
size: 1600*1450*1600



TS-03A

push shoulder trainer

- The movement trajectory is more in line with ergonomic principles, and each movement brings a smooth and silky experience;
- The design of multiple gears and special treatment of elbow pads can adapt to people with different shoulder widths;
- Scientific design makes it easier for trainers to achieve appropriate force angles when using it;

Standard counterweight: 60KG
size: 1310*1270*1600



TS-002

Butterfly machine trainer

- The product collection combines chest clamping and expansion exercises, with a more scientific angle of force application and precise stimulation of target muscle groups;

- The boom adopts a pivot connection structure, which is designed reasonably and suitable for people with different arm spans;The clever design of plastic parts and decorative covers at various motion connections and pivot points greatly improves the performance of the equipment

- Combining electrostatic spraying with automotive dust-free baking paint technology, the texture is warm and has stronger wear resistance and scratch resistance

Standard counterweight: 80KG
size: 1360*1710*1600



TS-02A

Straight-arm chest press machine

- The product collection combines chest clamping and expansion exercises, with a more scientific angle of force application and precise stimulation of target muscle groups;

- The boom adopts a pivot connection structure, which is designed reasonably and suitable for people with different arm spans;The clever design of plastic parts and decorative covers at various motion connections and pivot points greatly improves the performance of the equipment

- Combining electrostatic spraying with automotive dust-free baking paint technology, the texture is warm and has stronger wear resistance and scratch resistance

Standard counterweight: 60KG
size: 1460*1200*2060



TS-004

rowing machine

- Precise aluminum slide rail adjustment structure, silent and noise reducing, smooth and stable;

- The design of the auxiliary handle allows trainers to perform one handed rotation training;

- Using ergonomic design to achieve a more scientific and reasonable angle of force application;

Standard counterweight: 100KG
size: 1400*1260*1600



TS-006

Biceps trainer

- Subverting the traditional form of biceps training and innovating structural design;

- The rotatable handle increases the flexibility and comfort of training;

- The design shape of the rope reel ensures more uniform force distribution at various positions of the equipment during training;

Standard counterweight: 100KG
size: 1400*1260*1600

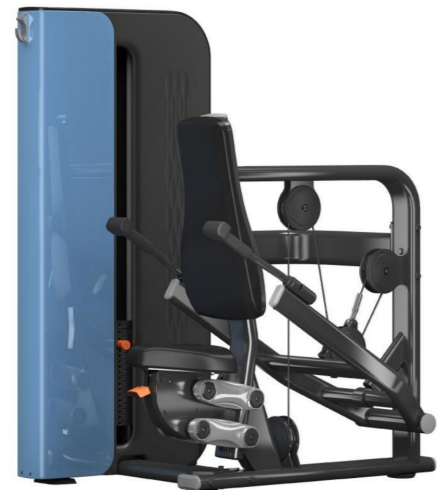

TS-005 **triceps trainer**

- The perfect rope-walking design complements the design style of the entire series;
- The angle formed by the back cushion and the cushion is more scientific, making it easier for the trainer to press down and lift up more weight;
- The handlebars rotating left and right increase the diversity of training and adapt to people with different shoulder widths;

Standard counterweight: 100KG
size: 1360*1710*1600



TS-008 **Upper arm flexion and extension trainer**

- Increase the self-weight of the equipment, be calm and solid, and the shape is domineering and heavy
- The design of the two-way handle increases the diversity of training and adapts to people with different shoulder widths;
- The humanized design of the double-layered pedal makes it more convenient and safe to use;

Standard counterweight: 60KG
size: 1460*1200*2060



TS-011 **rotational trainer**

- Absorb international sports equipment design concepts and greatly increase structural stability;
- Seiko pressure bearings are smoother and more stable when used;
- Mute processing, excellent shock absorption and noise reduction effect;

Standard counterweight: 60KG
size: 1400*1260*1600



TS-012 **high pull back trainer**

- 3.0+ metal pipes, solid materials, thick and stable;
- Seiko hardware accessories-pulleys, wire ropes, bearings and other core components are fully benchmarked with European industrial standards.
- The force angle is more scientific, accurately stimulates the target muscles, and the training effect is excellent;

Standard counterweight: 100KG
size: 1400*1260*1600



TS-009 **back muscle trainer**

- The design structure is simple and tough, which is more in line with the aesthetics of current consumers;
- A more scientific angle of the foot tube makes it easier to apply force;
- Multi-gear adjustment of foam can adapt to people of different heights;

Standard counterweight: 100KG
size: 1360*1710*1600



TS-010 **Abdominal flexion trainer**

- Multiple grasping postures to adapt to users of different heights;
- Innovative cushion shape helps stabilize the pelvis and better isolate abdominal muscles;
- Increase the weight of the equipment, make it more stable in use, and improve the sports experience;

Standard counterweight: 60KG
size: 1460*1200*2060



TS-012c **A high pull back trainer**

- Multi-gear adjustment of foam adapts to people of different heights;
- Use ergonomic design to make the force perspective more scientific and reasonable;
- Mute processing, excellent shock absorption and noise reduction effect;

Standard counterweight: 100KG
size: 1400*1260*1600



TS-013 **Seated leg curl machine**

- Elbow pads and handles that can be adjusted up and down to improve training comfort;
- Front and rear adjustment of the seat and multi-gear selection of leg press foam adapt to different groups of people;
- Reasonable structural design, more convenient back pad, shin pad and amplitude adjustment;

Standard counterweight: 80KG
size: 1400*1260*1600



TS-13A A horizontal leg curl machine

- . The seat leather material has been upgraded to 2.0, which is comprehensively thickened, tough and wear-resistant, and has a longer service life;
- . Comfortable and anti-sweat design to comprehensively enhance the feel of use;
- . Reasonable structural design, more convenient back pad, shin pad and amplitude adjustment;

Standard counterweight: 80KG
size: 1360*1710*1600



TS-014 leg stretcher

- . The device connectors are made by Seiko and are benchmarked with European industrial standards;
- Standard counterweight: 60KG
size: 1460*1200*2060



TS-017 Seated calf trainer

- .The cushion sliding group is adjustable up and down to meet different training itinerary options;
- . The pulley running rope is hidden, making the overall equipment more beautiful;
- . Seiko hardware accessories fully benchmark European industrial-grade standards;

Standard counterweight: 100KG
size: 1400*1260*1600



TS-018 leg curl machine

- .Absorb international cutting-edge sports mechanics technology, balance the force ratio, and evenly exert force throughout the entire process;
- . The angle adjustment of the seat and the front and back adjustment increase the flexibility of training;
- . The humanized front bezel design makes the sports experience more comfortable;

Standard counterweight: 100KG
size: 1400*1260*1600



TS-015 leg press machine

- . The structural design is more suitable for beginners and rehabilitated people;
- . the adjustable seat sliding set and training range can meet the needs of users of different body types;
- . The sitting posture is scientific and reasonable, reduces spinal pressure and reduces exercise risks;

Standard counterweight: 80KG
size: 1360*1710*1600



TS-15A Thigh stretching trainer

- . The adjustable structure of the chest pad is suitable for people of different heights;
- . Solid stainless steel slide bars are made of solid materials to fully ensure the stability and safety of the device;
- . The pedal assembly is sealed and processed to make the overall appearance of the device more beautiful;

Standard counterweight: 60KG
size: 1460*1200*2060



TS-019 Leg abduction trainer

- .Leather material is tough and wear-resistant, and has a longer service life.
- .The force angle is more scientific and accurately stimulates the target muscles
- . The movement trajectory is more ergonomic and reduces the burden on the body.

Standard counterweight: 100KG
size: 1400*1260*1600



Smith's hip leg trainer

size: 196*17*130cm



Smith's hip leg trainer

size: 196*17*130cm





Two-way squat trainer

size: 2032*1650*1660mm

Standard counterweight: 192KG



Belt squat trainer

size: 1741*978*1055mm

Standard counterweight: 107KG



Prone straight leg back swing trainer

size: 1343*825*1094mm

Standard counterweight: 75KG



Standing hip abduction trainer

size: 1805*939*1518mm

Standard counterweight: 128KG



Shoulder lift trainer

编号Number: CX-4002

尺寸size: 401 *78*228cm

重量weight:458KG



Little bird

编号Number: Cx-8022

尺寸size: 112* 158*242

重量weight:575KG



Four stations

编号Number: Cx-8049

尺寸size:364★ 188*239cm

重量weight:820KG



Five stations

编号Number: CX-8051

尺寸size: 364*188*239cm

重量weight: 80KG*3/100KG*2



Eight People Station

编号Number: Cx-8052

尺寸size: 561*364*239cm

重量weight:80KG*3/100KG*2



Four stations

编号Number: Cx-8050

尺寸size:561*364*239cm

重量weight:80KG*3/100kg*2



坐姿推肩训练器

PT03

SUPER DELTOID PRESS

整机尺寸size:2130X1560X1630mm



划船训练器

PT04

SUPER ROWING

整机尺寸size:1860X1560X1630mm



上斜推胸训练器

PT03A

SUPER INCLINED CHEST PRESS

整机尺寸size:1850X1560X1880mm



T型划船训练器

PT04A

T-BAR ROW

整机尺寸size:1570X1560X1630mm



剪刀拉背训练器

PT04B

SUPER ROWING CIRCULAR

整机尺寸size:2210X1560X1630mm



坐姿三头训练器

PT07

FRENCH PRESS MACHINE

整机尺寸size:2010X1560X1630mm



二头肌训练器

PT06

ALTERNATE CURLING MACHINE

整机尺寸size:1210X1710X1360mm



多功能拉杆训练器

PT08

FRONT DORSY BAR

整机尺寸size:1510X1540X1630mm



手臂下压背部训练器

PT09

SUPER PULLOVER MACHINE

整机尺寸size:2270X1370X1630mm



高位划船训练器1

PT12

SUPER LAT MACHINE CONVERGENT

整机尺寸size:2110X1560X2015mm



坐姿拉背训练器

PT10

SUPER POWER ROW

整机尺寸size:1550X1560X1880mm



高位下拉训练器

PT12B

SUPER LAT PULLDOWN CIRCULAR

整机尺寸size:1620X1560X2180mm



背肌下拉训练器

PT15A

SUPER HIGH ROW

整机尺寸size:2970X1560X2140mm



45度倒蹬训练器

PT15A

SUPER LEG PRESS 45°

整机尺寸size:2580X1560X1630mm



钟摆深蹲训练器

PT13

SUPER PENDULUM SQUAT

整机尺寸size:2080X1560X1880mm



站姿髋外展训练器

PT17

STANDING ABDUCTOR

整机尺寸size:1900X1560X1630mm



塔式推胸举肩训练器

PT18

POWER SMITH DUAL SYSTEM UPPER

整机尺寸size:1860X2030X1990mm



倒蹬训练器

PT20

VERTICAL LEG PRESS

整机尺寸size:2100X2085X2090mm



塔式推胸训练器

PT19

POWER SMITH MACHINE DUAL SYSTEM

整机尺寸size:1820X1930X1505mm



臀桥训练器

PT21

HIP THRUST

整机尺寸size:2220X1560X1630mm

MT500C-T

商用旋转投屏跑步机 Projection treadmill



MT500C-T

旋转投屏

Rotating screen projection



智能应用 Smart Application



21.5吋旋转投屏



蓝牙



WI-FI



手机投屏



实时数据

功能参数 Functional Parameter

产品功率 Rated power of motor	1.8KW
速度范围 Speed range	1-20KM/H
坡度范围 Incline range	0-20%
整机尺寸 Unit Dimensions	横屏 2062×1014×1757 (mm) 竖屏 2062×1014×1860 (mm)
跑步面积 Running surface	580×1540 (mm)
最大承重 Max user weight	150KG

K800 TREADMILL

商用跑步机

Commercial Treadmill



K800

LED数字屏



TFT触摸屏



智能应用 Smart Application



18.5吋触摸屏



蓝牙



WI-FI



社交互联



实时数据



实景体验

功能参数 Functional Parameter

速度范围 Speed range	1-20KM/H
坡度范围 Incline range	0-20%
整机尺寸 Unit Dimensions	2200×910×1850 (MM)
跑步面积 Running surface	1530×600MM
最大承重 Max user weight	150KG

PN7000

商用跑步机

Commercial Treadmill



PN7000



功能参数 Functional Parameter

产品功率 Rated power of motor	3.0HP (2.2KW)
速度范围 Speed range	1-20KM/H
坡度范围 Incline range	0-20%
整机尺寸 Unit Dimensions	2250×990×1680 (MM)
跑步面积 Running surface	1600×530MM
产品净重 Unit weight	240KG
最大承重 Max user weight	150KG

X8500PB



X8600PB

DIM:	2180*910*1780 mm
PS:	3HP/2200W/AC
AngleRange:	0~15°
SpeedRange	1~20km/h
Weight:	210 kg
Console:	LED 背光显示
entertainmnt	23.8 英寸 LCD 显示器

规格SPEC

The X8600PB series makes a stunning debut, captivating users with its sleek aesthetic. The treadmill's full-metal handrails and pillars blend flawlessly with the main frame, creating a seamless unity. Whether you prefer the understated elegance of the gray finish or the vibrant energy of the silver option, this series becomes a standout centerpiece in any cardio workout area.

概述Abbreviation

X8500PS



X8600PS

DIM:	2180*910*1780 mm
PS:	3HP/2200W/AC
AngleRange:	0~15°
SpeedRange	1~20km/h
Weight:	210 kg
Console:	LED 背光显示
entertainmnt	23.8 英寸 LCD 显示器

规格SPEC

The launch of the X8600PS series brings users a refreshing visual experience. Its all-metal handrails and support columns seamlessly integrate with the treadmill body, creating a striking visual statement in any cardio zone—whether through the sophisticated elegance of the gray model or the dynamic energy of the silver version.

概述Abbreviation

X8500P



X8600P

DIM:	2180*910*1530 mm
PS:	3HP/2200W/AC
AngleRange:	0~15°
SpeedRange	1~20km/h
Weight:	200 kg
Console:	LED 背光显示

规格SPEC

The X8600P series makes a stunning debut, captivating users with its sleek aesthetic. The treadmill's full-metal handrails and pillars blend flawlessly with the main frame, creating a seamless unity. Whether you prefer the understated elegance of the gray finish or the vibrant energy of the silver option, this series becomes a standout centerpiece in any cardio workout area.

概述Abbreviation

X8600



X8600

DIM:	2180*920*1460 mm
PS:	3HP/2200W/AC
AngleRange:	0~15°
SpeedRange	1~20km/h
Weight:	196 kg
Console:	LED 背光显示

规格SPEC

The launch of the X8600 series brings users a refreshing visual experience. Its all-metal handrails and support columns seamlessly integrate with the treadmill body, creating a striking visual statement in any cardio zone—whether through the sophisticated elegance of the gray model or the dynamic energy of the silver version.

概述Abbreviation

X7200AS



X7200AS

DIM:	2140*910*1650 mm
PS:	3HP/2200W/AC
AngleRange:	0~15°
SpeedRange	1~20km/h
Weight:	190 kg
Console:	LED 背光显示

规格SPEC

X7200AS - The Smart Choice for Value-Driven Fitness
Cost-Efficient Performance Engineered for High-Volume Operations

概述Abbreviation

X8600



X7200A

DIM:	2140*910*1400 mm
PS:	3HP/2200W/AC
AngleRange:	0~15°
SpeedRange	1~20km/h
Weight:	180 kg
Console:	LED 背光显示

规格SPEC

X7200A – The Ultimate Cost-Efficient Powerhouse for Fitness Enthusiasts
Engineered for maximum value without compromise, this budget-friendly workhorse delivers:
Logistics Advantages

概述Abbreviation

Non-Motorized Treadmill



A7000

DIM: 1840*900*1651 mm
PS: Non-motorized | Self-Propelled
WT: 138 kg
CONS: LED 背光显示

A7000 Treadmill – Precision Engineered for Elite Performance

For Athletes Who Demand Total Control

规格SPEC

概述Abbreviation

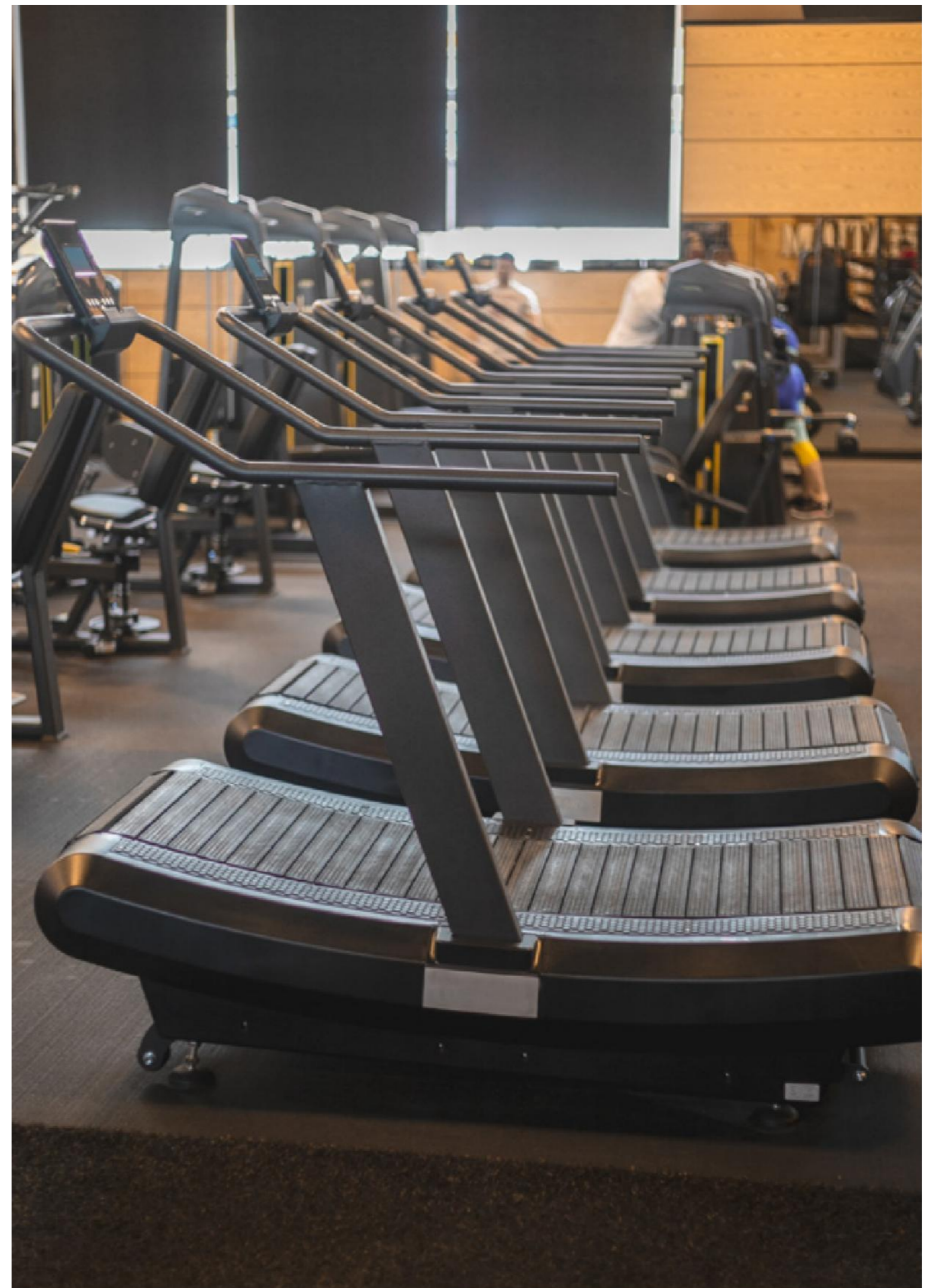



▶ **CT-100**

Self- Powered Treadmill
自动力跑步机
L/长: 2000mm W/宽: 890mm
H/高: 1420mm WEIGHT/重量: 199kg



LED screen / 按键屏



▶ **CT-300**

Self- Powered Treadmill
自动力跑步机
L/长: 1800mm W/宽: 800mm
H/高: 1420mm WEIGHT/重量: 145kg



特殊的弧形跑步基础设计减少了膝关节的伤害，更符合人体工程学。
Special arc running base design reduced the hurt on the knee joint and more suit for Ergonomics.



不再依赖外部电源，大大节约了成本。
No longer rely on external power, saves the cost greatly.



依靠自我机制，不再被动运行，速度可由用户自由控制。
Relying on self mechanics, it no longer runs passive, the speed can be controlled freely by user.



履带行走带采用弹性橡胶制成，坚固耐用，外观优雅。
Crawler running belt made of elastic rubber with aluminum alloy frameworks inside, solid and durable, and elegant in appearance.



稳定的双扶手设计，确保使用者的安全。
Stable double-armrest design, ensuring the safety of user.



▶ **CT-400**

Self- Powered Treadmill
自动力跑步机
L/长: 1470mm W/宽: 800mm
H/高: 1550mm WEIGHT/重量: 98kg

M-8809EL

商用椭圆机 Commercial elliptical machine



商用椭圆机



功能参数 Function Parameter

整机尺寸 Unit Dimensions	2210×730×1635 (mm)
包装尺寸 Packing dimensions	2250×810×940 (mm)
净重 Unit weight	130kg
最大承重 Max user weight	150kg

舒适体验 Comfortable experience

Display	7-inch LCD Display
Preset Programs	3 Programs
Resistance Levels	20 Levels
Resistance Adjustment	Magnetic Resistance System
Drive System	Belt Drive
Soft Armrests	Cushioned for Comfort

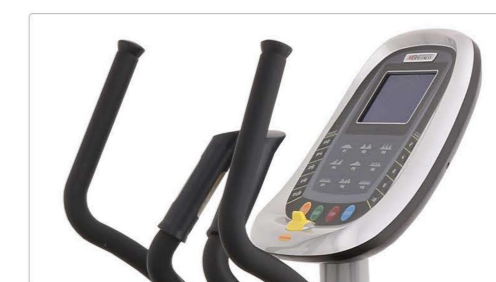

M-8808EL

商用椭圆机 Commercial elliptical machine



商用椭圆机



功能参数 Function Parameter

整机尺寸 Unit Dimensions	2100×723×1755 (mm)
包装尺寸 Packing dimensions	2180×810×990 (mm)
净重 Unit weight	155kg
最大承重 Max user weight	150kg

舒适体验 Comfortable experience

Display	7-inch LCD Display
Preset Programs	3 Programs
Resistance Levels	15 Levels
Resistance Adjustment	Magnetic Resistance System
Drive System	Belt Drive
Soft Armrests	Cushioned for Comfort

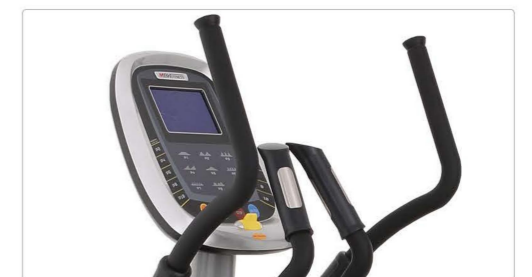

M-8810

体适能机 Physical fitness machine



Functional Walker

体适能机



功能参数 Function Parameter

整机尺寸 Unit Dimensions	1505×920×1595 (mm)
包装尺寸 Packing dimensions	1660×990×1580 (mm)
净重/毛重 Unit weight	188/244kg
最大承重 Max user weight	150kg

舒适体验 Comfortable experience

- Sensitive Braking
- Belt Drive
- Premium Saddle
- Dual Protective Covers
- Reinforced Frame
- Ergonomic Handlebars
- Instant Stop
- Silent Operation
- Plush Comfort
- Enhanced Safety
- Heavy-Duty Construction
- Multi-Grip Positions



椭圆机 Elliptical machine

700 椭圆机(Elliptical machine)

净重/毛重 (N. W/G. W) : 206KG/230KG

产品尺寸 (PRODUCT SIZE) : 2100*700*1700MM (L*W*H)

包装尺寸 (PACKING SIZE) : 2210*750*1750MM (L*W*H)



椭圆机 Elliptical machine

B06 椭圆机(Elliptical machine)

商用椭圆机 Elliptical

Size:2100*760*1820mm

Machine Weight:100kg



M-5810

豪华动感单车 Luxury spinning bike



Indoor Bike

豪华动感单车



功能参数 Function Parameter

整机尺寸 <small>Unit Dimensions</small>	1225×630×1170 (mm)
包装尺寸 <small>Packing dimensions</small>	1150×430×970 (mm)
净重/毛重 <small>Unit weight</small>	73/80kg
最大承重 <small>Max user weight</small>	150kg

舒适体验 Comfortable experience

- Sensitive Braking
- Belt Drive
- Premium Saddle
- Dual Protective Covers
- Reinforced Frame
- Ergonomic Handlebars
- Instant Stop
- Silent Operation
- Plush Comfort
- Enhanced Safety
- Heavy-Duty Construction
- Multi-Grip Positions

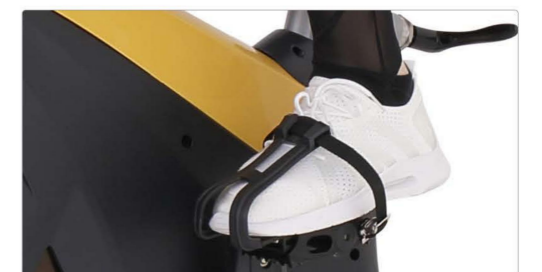

M-5807

动感单车 spin bike

Indoor Bike



功能参数

整机尺寸 Unit Dimensions	1200×620×1240 (mm)
包装尺寸 Packing dimensions	1160×350×1020 (mm)
净重/毛重 Unit weight	57/63kg
最大承重 Max user weight	150kg

舒适体验

Resistance Adjustment	Stepless Resistance Control (Aluminum Alloy Adjustment System)	
Drive System	Chain Drive	
Reinforced Pedals	Anti-Slip & Wear-Resistant, Enhanced Comfort	
Weighted Flywheel	18kg Flywheel for Stable Riding Experience	

M-5809

动感单车 spin bike

Indoor Bike



功能参数

整机尺寸 Unit Dimensions	1158×620×1126 (mm)
净重/毛重 Unit weight	66/71kg
最大承重 Max user weight	150kg

舒适体验

Resistance Adjustment	Stepless Resistance Control (Aluminum Alloy Adjustment System)	
Drive System	Chain Drive	
Reinforced Pedals	Anti-Slip & Wear-Resistant, Enhanced Comfort	
Weighted Flywheel	18kg Flywheel for Stable Riding Experience	



MND-D16

Magnetic Resistance Exercise Bike

- 1.The pedal is installed with Morse taper, which is more closely matched and not easy to be damaged
- 2.Commercial grade pure aluminum rear flywheel, high-speed operation without drifting
- 3.Oversized steel frame, with better overall corrosion resistance
- 4.Aerodynamics and circular design

5.Stepless magnetic control regulation

Product weight: 48.5kg

Floor area: 1190 (L) *590 (W) *100 (H)

Tube type: flat oval tube 120*40*2.5t, flat oval tube 100*50*2.5t

MND-D16

磁阻力调节动感单车

1. The pedal installation adopts a Morse taper design, ensuring a tighter fit and greater durability.
2. Commercial-grade pure aluminum rear flywheel provides stable high-speed operation without wobbling.
3. The oversized steel frame offers superior overall corrosion resistance.
4. Featuring aerodynamic principles and a circular design for enhanced performance.
5. Stepless magnetic resistance adjustment

Product weight: 48.5 kg

Dimensions: 1190 (L) × 590 (W) × 100 (H) mm

Frame material: Flat oval tube 120×40×2.5T, flat oval tube 100×50×2.5T



Recumbent Exercise **Bike**



M5100S 单车(Staircase machine)

单车Staircase machine

Size:1600*615*1600 mm

Machine Weight:100kg

M5100S

: DIM:	2180*910*1780 mm
PS:	3HP/2200W/AC
AngleRange:	0~15°
SpeedRange:	1~20km/h
Weight:	210 kg
Console:	LED 背光显示
entertainmnt	23.8 英寸 LCD 显示器

This ergonomically designed recumbent bike features a comfortable reclined position, making it ideal for low-impact joint mobility training. The premium leather seat and backrest provide exceptional comfort during extended workouts.

Recumbent Exercise **Bike**



D09 风扇单车(Staircase machine)

风扇单车Staircase machine

Size:1270*600*1220MM (L*W*H)

Machine Weight:67KG/70KG

RECUMBENT BIKE

Specifications

Dimensions (L x W x H): 67 x 23 x 53 in / 170 x 58 x 135 cm

Product Weight: 179 lb / 81 kg

Power: 120 volt, 15 amp circuit

Total Workouts: 12

Resistance Levels: 25

Minimum Watts: 22 (level 1 at 20 RPM)

Maximum Watts: 500 (level 25 at 150 RPM)

Entertainment: 16 in / 40.6 cm LCD Capacitive Touchscreen with wireless charging, audio jack, and Bluetooth® headphones

Accessories: Reading Rack, Dual Water Bottle Holder Optional - Cable Management



Storm Grey

Refined colorways with dark Tungsten covers and two frame color options, Storm Grey and Black Pearl.



Black Pearl

RECUMBENT BIKE

Specifications

Dimensions (L x W x H): 65 x 23 x 53 in / 165 x 58 x 135 cm

Product Weight: 179 lb / 81 kg

Power: 120 volt, 15 amp circuit

Total Workouts: 12

Resistance Levels: 25

Minimum Watts: 22 (level 1 at 20 RPM)

Maximum Watts: 500 (level 25 at 150 RPM)

Console Features: 15 in / 38.1 cm LCD Capacitive Touch Screen with mobile device charger, audio jack and optional Smart Watch Connector for Apple Watch

Accessories: Reading Rack, Dual Water Bottle Holder Optional - Cable Management



Storm Grey

Refined colorways with dark Tungsten covers and two frame color options, Storm Grey and Black Pearl.



Black Pearl

RECUMBENT BIKE

Specifications

Dimensions (L x W x H): 65 x 23 x 57 in / 164 x 58 x 132 cm

Product Weight: 179 lb / 81 kg

Power: 120 volt, 15 amp circuit

Total Workouts: 12

Resistance Levels: 25

Minimum Watts: 22 (level 1 at 20 RPM)

Maximum Watts: 500 (level 25 at 150 RPM)

Console Features: 10 in / 25.4 cm LCD Capacitive Touchscreen, Mobile Device Charger, and Audio Jack

Accessories: Reading Rack, Dual Water Bottle Holder Optional - Cable Management



Storm Grey

Refined colorways with dark Tungsten covers and two frame color options, Storm Grey and Black Pearl.



Black Pearl

RECUMBENT BIKE

Specifications

Dimensions (L x W x H): 43 x 21 x 57 in / 109 x 53 x 145 cm

Height with PVS: 63 in / 160 cm

Product Weight: 179 lb / 81 kg

Power: Self-powered

Total Workouts: 12

Resistance Levels: 25

Minimum Watts: 22 (level 1 at 20 RPM)

Maximum Watts: 500 (level 25 at 150 RPM)

Entertainment: Optional - 15.6 in / 39.6 cm Personal Viewing System (PVS)

Accessories: Reading Rack, Dual Water Bottle Holder Optional - Cable Management



Storm Grey

Refined colorways with dark Tungsten covers and two frame color options, Storm Grey and Black Pearl.



Black Pearl

Recumbent Exercise **Bike**



T01 楼梯机 (Stair climber)

楼梯机 Stair climber

Size: 1290*660*1110 (L*W*H)

Machine Weight: 181KG/215KG



SUPERO风磁双阻划船器

SUPERO 单车(Staircase machine)

单车Staircase machine

Machine Weight: 300lbs /136kg



SUPERO

DIM:	2180*910*1780 mm
PS:	3HP/2200W/AC
AngleRange:	0~15°
SpeedRange:	1~20km/h
Weight:	210 kg
Console:	LED 背光显示
entertainmnt	23.8 英寸 LCD 显示器

The wind resistance rowing device uses a resistance system that combines wind resistance and magnetic resistance. Users can change it by themselves through frequency and rhythm.

Change resistance, whether fitness enthusiasts or professional athletes, can find the training intensity that suits you

A comprehensive 3D intelligent body measurement expert Visbody-D

Pro33D Smart Body Assessment Expert is a new series of 3D smart body assessment products launched by V-shape Technology. It first to adopt AI vision and optical 3D reconstruction technology to generate high-precision real 3D human models, providing users with 360° full-dimensional body assessment services. In addition to body shape, posture, body composition, and body circumference, it has newly added features such as 3D true skeletal display, spinal function evaluation, and foot electrode constant temperature function. It is professional and comprehensive, using technology to warm hearts.





3D intelligent body measurement device

360-degree real 3D model turntable automatic rotation measurement, 12 core body composition analysis, 8 control and analysis recommendations, 9 millimeter-level circumference measurements, 9 professional posture assessments, 4 shoulder function evaluations

**Automatic rotation,
comprehensive
evaluation**

3D Smart Body Measurement Mirror

is a newly upgraded intelligent body measurement solution tailored for women's and postpartum health scenarios by V-shape. It is centered around their self-developed Body++ digital human health technology matrix. Combining their proprietary high-precision instant 3D/4D body scanning technology with their self-researched AI large models, it perfectly integrates various body assessment needs. Specifically designed for women's health scenarios, it provides intelligent, efficient, and convenient digital reconstruction of the human body and smart health analysis for clients such as yoga and Pilates, female body shaping, posture correction, maternity centers, and postpartum recovery.

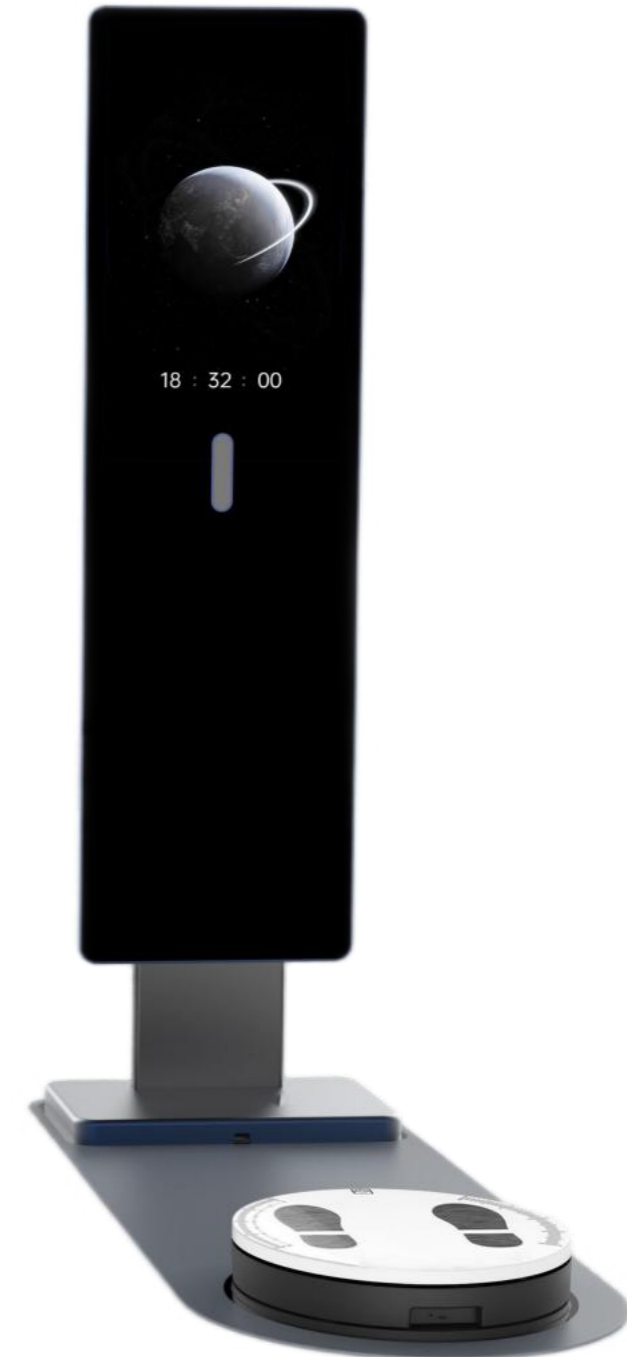



3D intelligent running assessment device

The Visbody-A600, designed for high-quality fitness institutions, professional sports teams, and sports rehabilitation centers, is an immersive 3D smart treadmill. It features Intel's dedicated autonomous driving visual sensors, with core processing power exceeding 3.6 GHz. Using proprietary ViScan motion capture technology, it performs over 39,800 intelligent posture analyses per minute, providing real-time running form monitoring and intelligent guidance for users to correct their running form and customize exercise plans based on analysis results. The product is designed by Porsche and top German sports equipment designer Milon, incorporating ergonomic principles to create a unique 'standing screen display' solution, paired with a 50-inch 4K LG imported screen, bringing indoor training into the immersive metaverse era. The Creator600's core components have undergone millions of tests to provide optimal performance and maximum safety for high-quality customers, making exercise training fun, intelligent, and efficient.

Intelligent fitness assessment training management device

The Smart Dynamic Physical Assessment and Training Machine, relying on V-shape Technology's innovative technology and the 'Military Physical Training Outline' standards, utilizes the Visbody-Engine algorithm engine technology. It is widely applied in military training fields to achieve real-time monitoring and personalized assessment of training movements, as well as prediction of exercise risks. Through scientific training recommendations, it helps military personnel enhance their physical fitness under various conditions, ensuring they reach optimal combat readiness and achieve higher levels of preparedness, thereby making positive contributions to national security and defense.





半框 half-frame

型号	TR-APTR-A1
宽度 W	1906mm
深度 L	1477mm
高度 H	2435mm



全框 full-frame

型号	TR-APTR-A3
宽度 W	1538mm
深度 L	1945mm
高度 H	2435mm





型号	U-A1
宽度 W	1906mm
深度 L	2631mm
高度 H	2435mm



型号	U-A2
宽度 W	1545mm
深度 L	4313mm
高度 H	2435mm



型号	U-A3
宽度 W	1545mm
深度 L	3159mm
高度 H	2435mm



型号	U-A4
宽度 W	1906mm
深度 L	2655mm
高度 H	2435mm

The height of the columns is 2435mm.
The hole diameter is 17.
The hole pitch is 50mm.
Sprayed by powder coating process.

Forms of logo display for multi - layer boards
36 laser - cut digital signs, safety arms with a static load -
bearing capacity of 500kg, multi - angle knurled pull - up
handles

产品特征



Rope Module System



Full-function rope module
全功能绳索模块R

型号	TR-APTR-B2
宽度 W	332mm
深度 L	1337mm
高度 H	2553mm
表面	粉末喷涂工艺



Single-ended sliding rope module
单头滑动绳索模块

型号	TR-APTR-B3
宽度 W	332mm
深度 L	1307mm
高度 H	2528mm
表面	粉末喷涂工艺



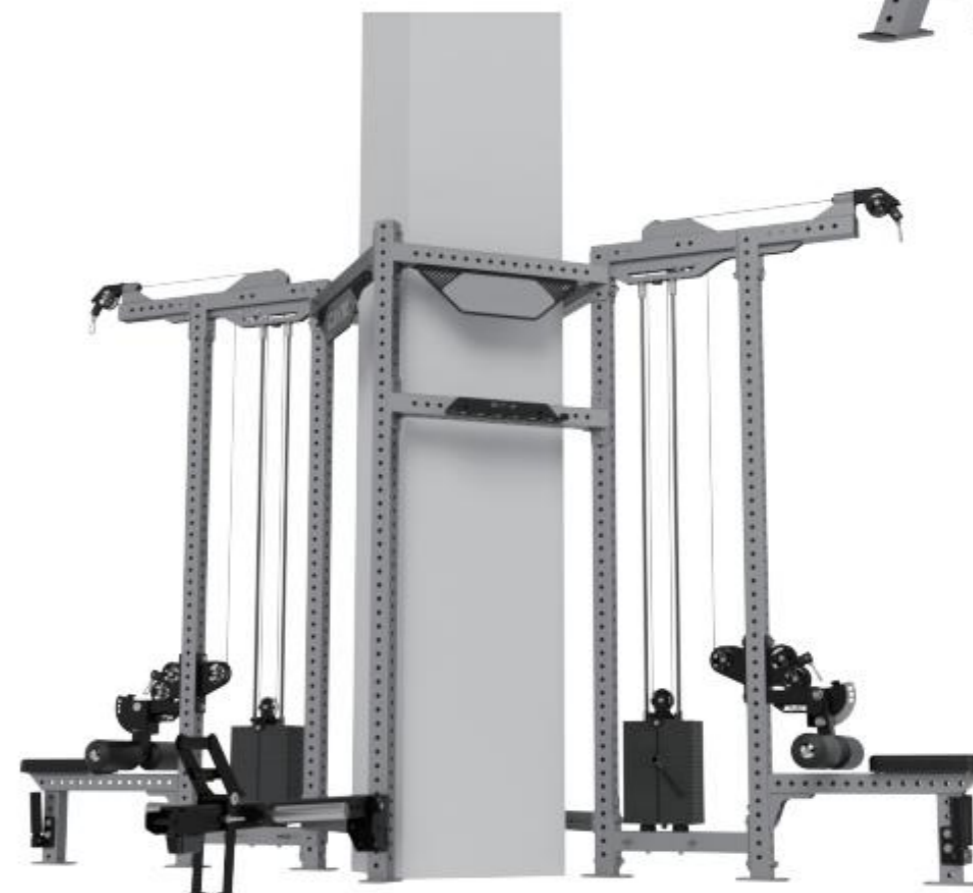



Adjustable Professional Push Arm



型号	宽度 W	深度 L	高度 H	重量
----	------	------	------	----

TR-APTR-C4	1890mm	338mm	1355mm	58kg
------------	--------	-------	--------	------





Belt Squat Accessories



型号	宽度W	深度L	高度H	重量
TR-APTR-C3	715mm	514mm	484mm	13kg





型号	宽度W	深度L	高度H	重量
----	-----	-----	-----	----

TR-APTR-C7	235mm	812mm	402mm	15kg
------------	-------	-------	-------	------



Seal Row Pad





型号	宽度 W	深度 L	高度 H
TR-APTR-C9	120mm	1091mm	656mm



Plyometric Training Swing Arm





专业全框举重台 Professional full-frame weightlifting table

型号	宽度 W	深度 L	高度 H
TR-APTR-C14	3124mm	3462mm	55mm



专业半框举重台 Professional half-frame weightlifting table

型号	宽度 W	深度 L	高度 H
TR-APTR-C15	3124mm	4012mm	55mm





功能性踏板 Functional pedal

型号	宽度 W	深度 L	高度 H
TR-APTR-C5	135mm	424mm	95mm



北欧挺/单腿深蹲 Nordic Hamstring Curl/One - leg Squat

型号	宽度 W	深度 L	高度 H
TR-APTR-C10	125mm	101mm	211mm



筋膜滚轮 Fascia roller

型号	宽度 W	深度 L	高度 H
TR-APTR-C8	590mm	125mm	270mm



战绳挂钩 War rope hook

型号	宽度 W	深度 L	高度 H
TR-APTR-C20	70mm	127mm	150mm



置物挂钩 storage hook

型号	宽度 W	深度 L	高度 H
TR-APTR-C10	125mm	101mm	211mm



多方位引体手柄 Multi-directional pull-up handle

型号	宽度 H	深度 L	高度 H
TR-APTR-C19	1033mm	276mm	106mm



炮筒 gun barrel

型号	宽度 W	深度 L	高度 H
TR-APTR-C18	166mm	85mm	435mm



引体杆 Pull-up bar

型号	宽度 W	深度 L	高度 H
TR-APTR-D6	1306mm	141mm	339mm



可调节引体把手 Adjustable pull-up handle

型号	宽度 W	深度 L	高度 H
TR-APTR-C2	340mm	300mm	365mm



臂屈伸双杠 Dip on parallel bars

型号	宽度 W	深度 L	高度 H
TR-APTR-C11	622mm	767mm	230mm



增强式训练挂杆 Enhanced Training Bar

型号	宽度 W	深度 L	高度 H
TR-APTR-C13	34mm	34mm	281mm



J型挂钩 J-shaped hook

型号	宽度 W	深度 L	高度 H
TR-APTR-C16	87mm	220mm	197mm



安全保护臂 Safety protection arm

型号	宽度 W	深度 L	高度 H
TR-APTR-C17	93mm	717mm	330mm



保护软带 Protect the soft belt

型号	宽度 W	深度 L	高度 H
TR-APTR-C23	170mm	1220mm	158mm



保护硬杆 Protect the rigid rod

型号	宽度 W	深度 L	高度 H
TR-APTR-C22	85mm	1245mm	171mm



高位下拉卡腿配件 High-level pull-down clamp leg accessories

型号
TR-APTR-C33



坐姿划船踏 Seated rowing pedal accessories

型号
TR-APTR-C34



半框标准配置

Half frame standard configuration



全框标准配置

Full frame standard configuration



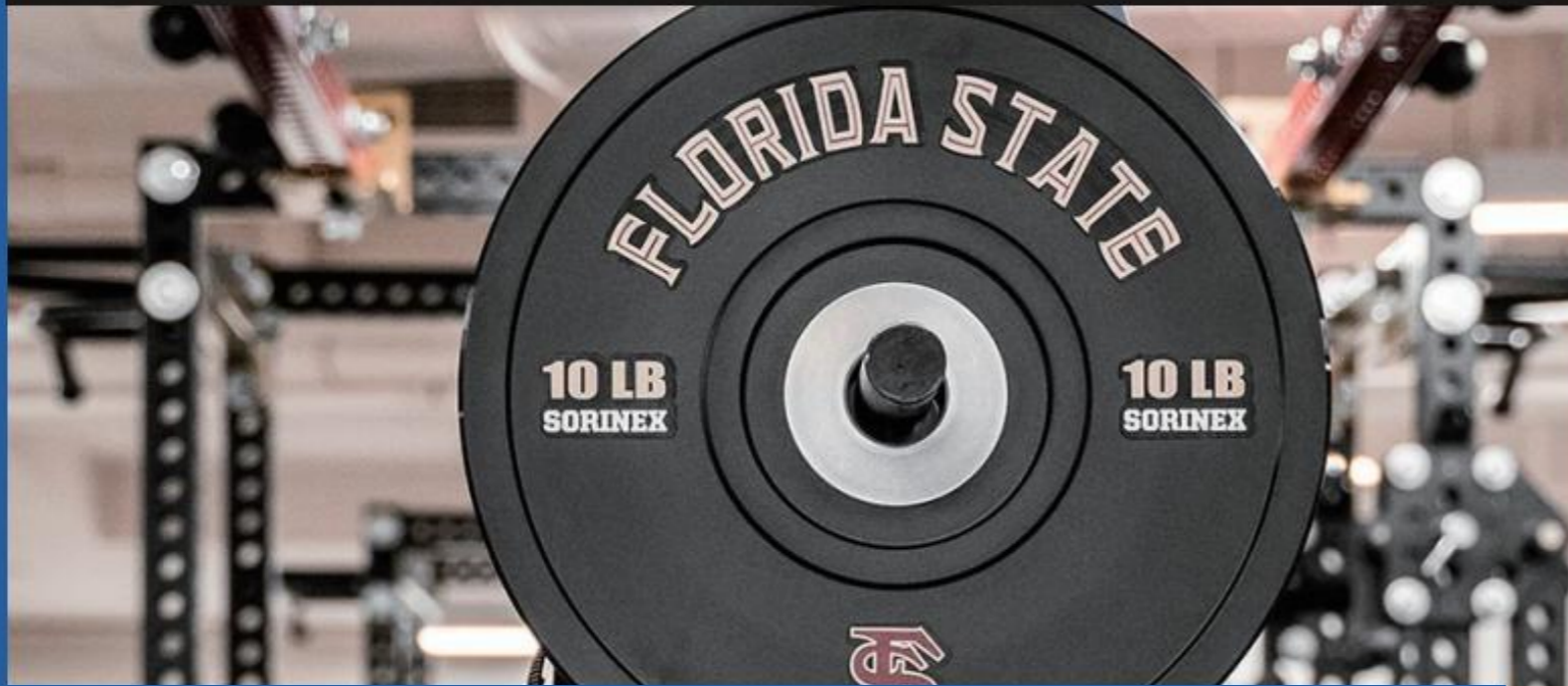

Custom Training Patch Logo





Custom Training Bench Logo



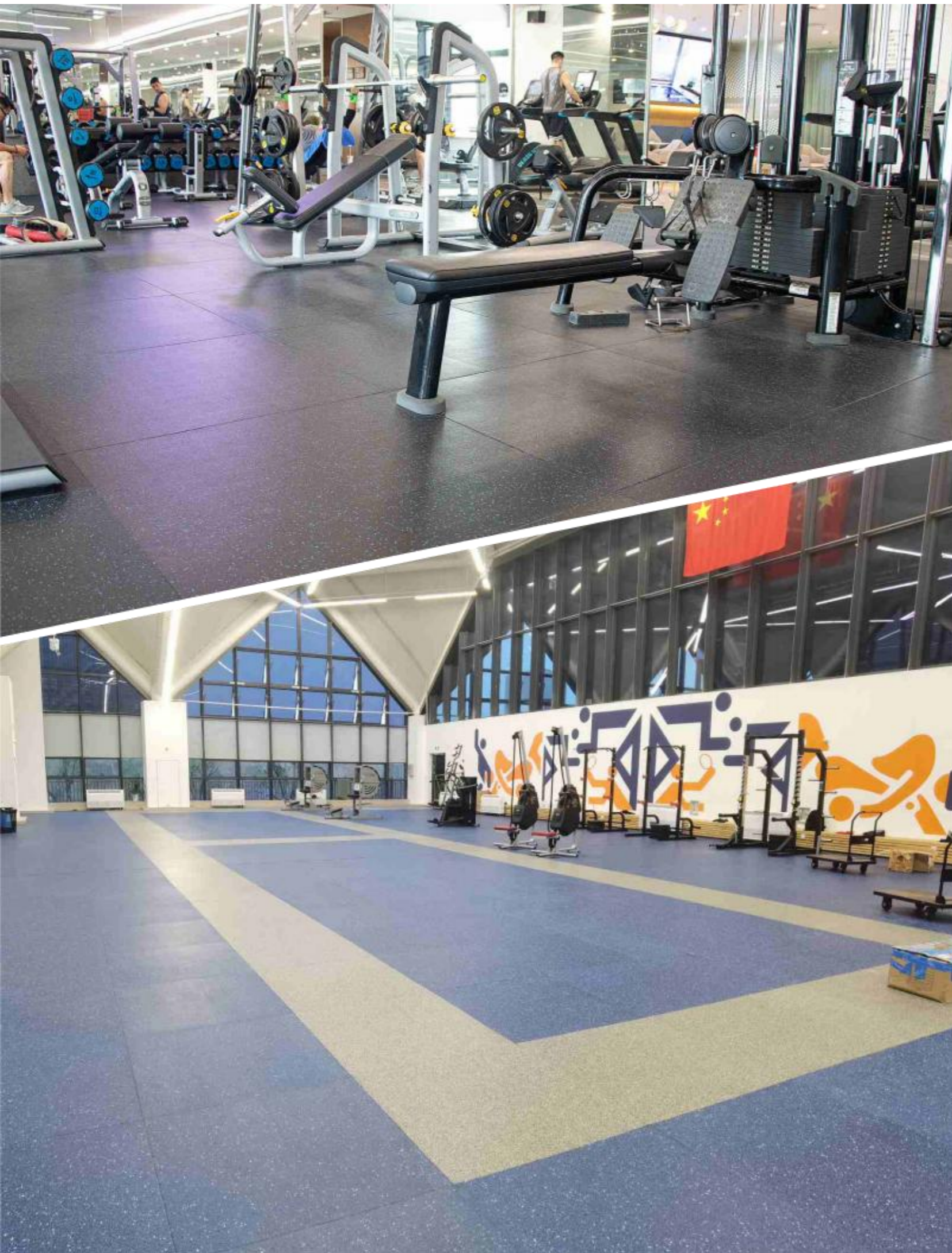

BUCKLED RUBBER TILE

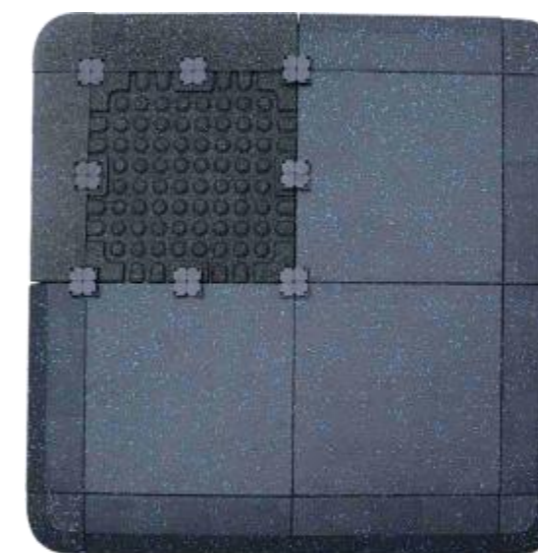

Buckled design , easy to install and disassemble; the edge is tightly sealed and not easy to move , with better integrity effect. High strength , good elasticity, stable and not easy for deformation , not easy to warping;The surface layer is custom made according to market demand , with high wear - resisting coefficient;Good damage absorption , provides comfortable sports protection on the ground.



PRODUCT NAME	STYLES	SPECIFICATIONS	THICKNESS
Buckled Rubber Tile	Flat Fluted	500×500mm/1000×1000mm	15/20/25/30/35/40/45/50mm



EDGE STRIP/ CORNER PAD

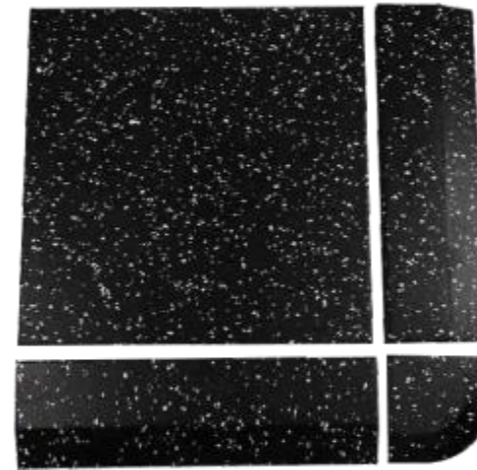

Developed specifically for locality sports/fitness ground.
It' S Safer to prevent kicking , and makes the zone more beautiful .
A Perfect solution to the field edge problem.



PRODUCT NAME

SPECIFICATIONS

THICKNESS

Edge strip / corner pad

Edge strip : 500mmx150mm
corner pad : 150mmx150mm

15/20/25/30/35/40/45/50mm



INTERLOCKING RUBBER MAT

It is composed of high density wear - resisting surface layer and elastic sound insulation bottom , interlocking tooth design , can be arbitrarily assembled; wear- resistant, anti -skid , softer, the sound insulation effect reached the national sound insulation improvement primary standard;widely used in various areas with high requirements for sound insulation and shock absorption.

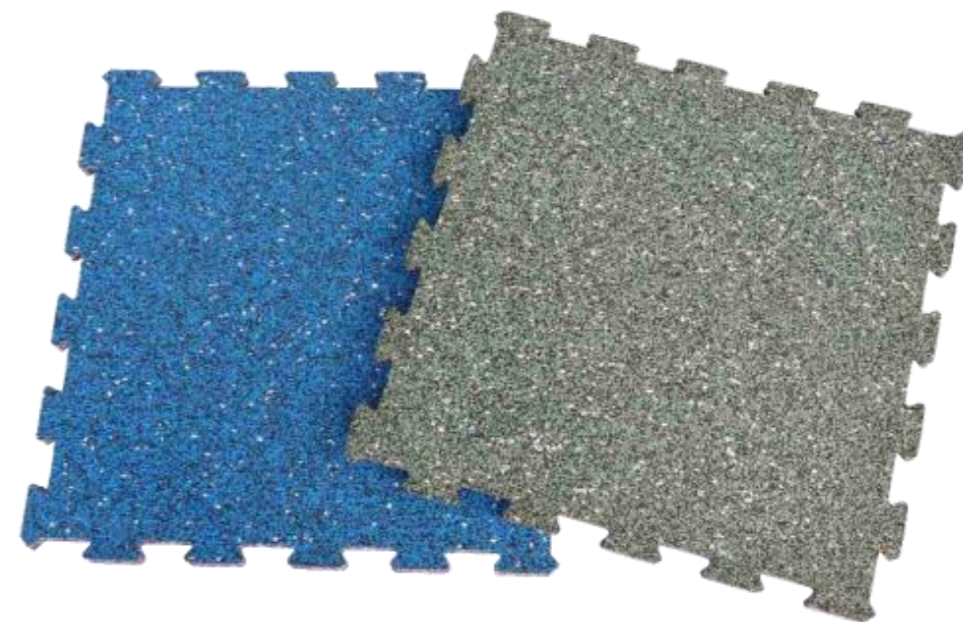
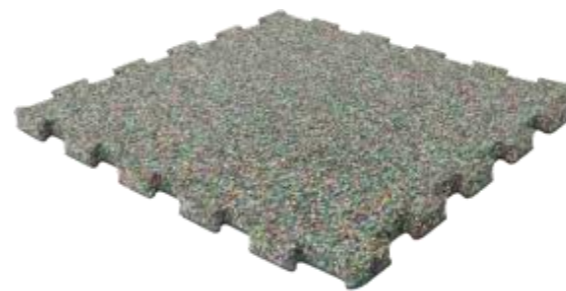

PRODUCT NAME

SPECIFICATIONS

EPDM CONTENT
E PDM含量

THICKNES
S 厚度

橡胶拼接地垫
Inter Locking Rubber Mat

500x500mm
1000x1000mm

15% /50% | 70%

8/10/12/15/20mm



INTERLOCKING MAT PRO

拼装地垫Pro

轻盈柔软，给予更好的触感与保护;色彩绚丽，更符合审美;无味环保，更亲肤;高强度耐磨层，比传统产品更耐用。

Light and soft, giving better touch feel and protection;
colorful, more in line with the aesthetic;
odorless and environmental protection, more skin friendly. with a high strength wear resistant Surface layer, more durable than traditional products.

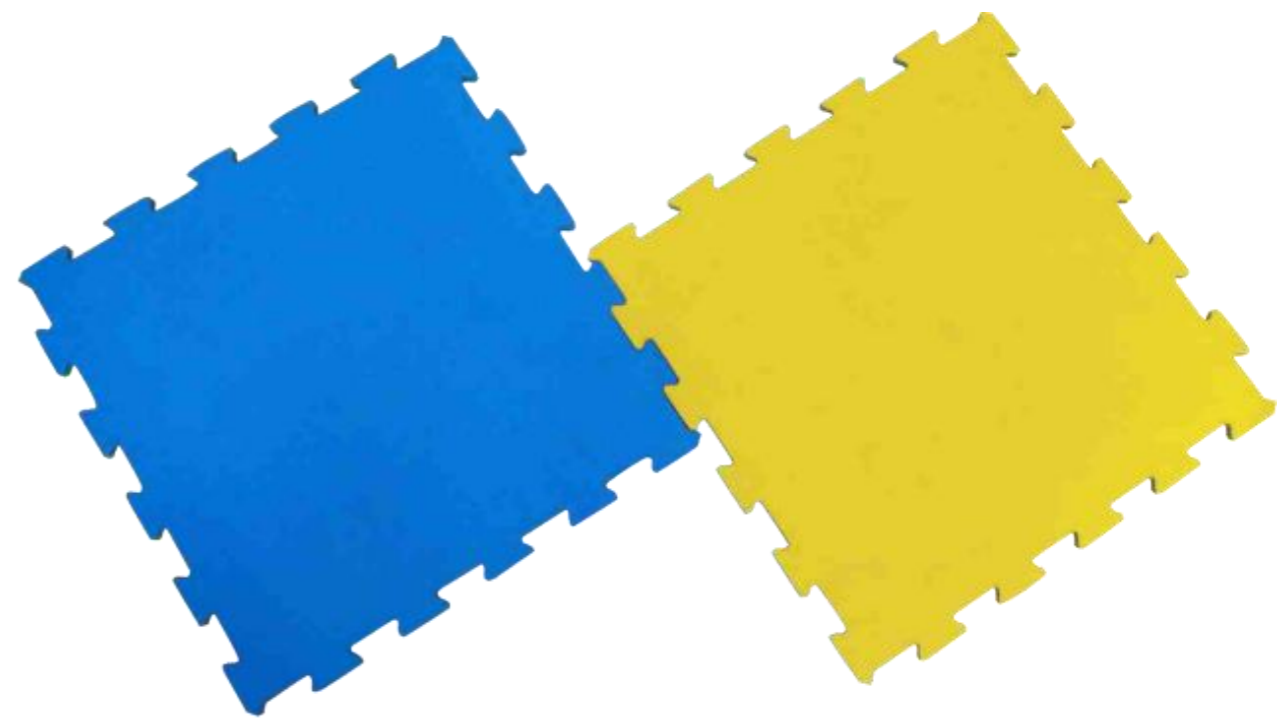

产品规格 定制
product specification customization



RUBBER ROLL

橡胶卷材



韧性极好，耐磨性佳，使用寿命长；色彩丰富，铺装整体效果好，是当前运动及生活防护场地地面材料的优先选择。

Excellent toughness, good wear resistance, long service life; Rich colors, good overall effect; A Priority selection in the Current sports and life protection ground materials.



PRODUCT NAME 产品名称	WIDT H 宽度	EPDM CONTENT E PDM含量	THICKNES S 厚度
橡胶卷材 Rubber Roll	1/1.25m	15% 150% 170% / 1.00%	3-12mm





BASKETBALL COURT SHOCK PAD

球场减震垫

一种对木地板篮球场起到很好减震和减噪作用的解决方案，耐冲击、弹性佳，有效减震，伤害吸收性能良好，防护木地板，减少运动伤害，同时有效减噪、减少噪音污染；防霉防潮，铺设简便，备受当前木地板篮球场建设者的青睐。

A ground solution that plays a good role in shock damping and noise reduction on the wooden floor basketball court. Good impact resistance, good elasticity, effective shock absorption, good damage absorption performance, protect wooden flooring, reduce sports injuries, and effectively reduce noise. Resistant to mildew and moisture, easy to install, favored by the wooden floor basketball court builders.

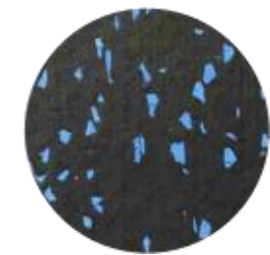
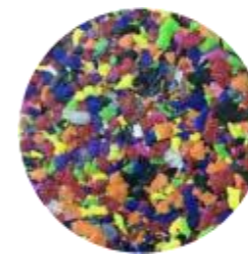

产品规格
product specification

定制
customization

复合橡胶地垫

Compound Rubber Mats

特点:

Feature

超厚面层 高弹性 易清洁 B2级防火 不易褪色 防烫防潮 无异味 耐老化!

Ultra-thick surface layer, high elasticity, easy to clean, Class B2 fireproof, not easy to fade, resistant to scalding and moisture, free of peculiar smell, and aging-resistant!



应用范围: Scope of application

应用于健身房、瑜伽室、棋牌室、台球室、普拉提馆及各种运动场所、休闲场所。

Applied to gyms, yoga rooms, chess and card rooms, billiards rooms, pilateshalls, and various sports and leisure venues.

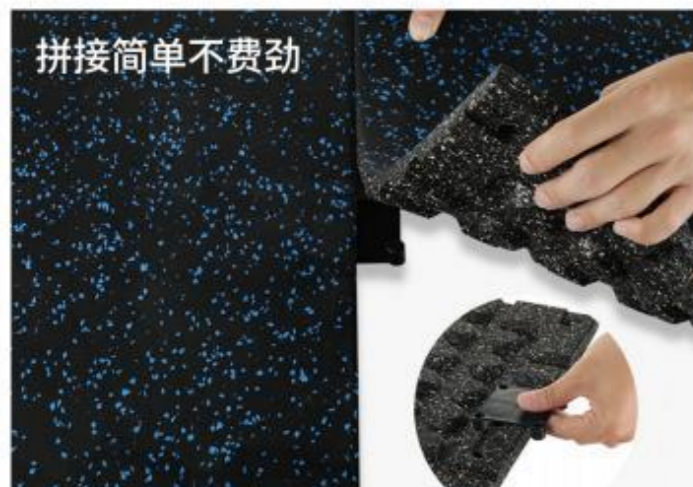

复合满天星色卡

Composite Manzanita Color Card



CYTY-01

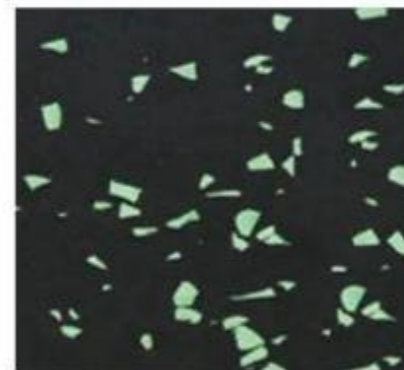

CYTY-02

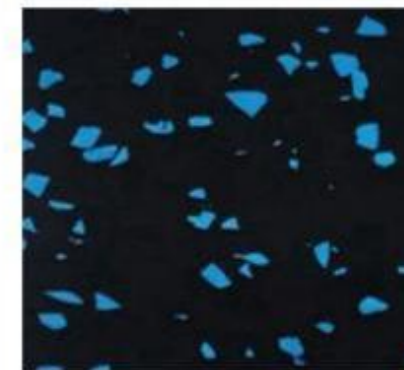

CYTY-03

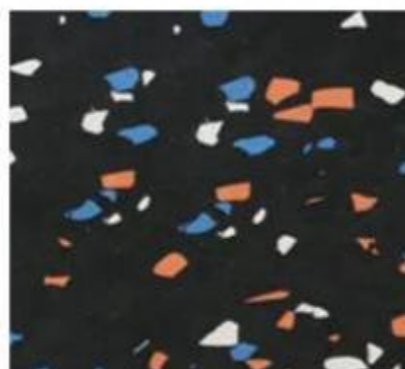

CYTY-04

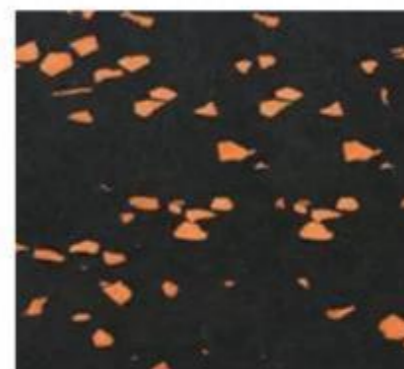

CYTY-05



CYTY-06



CYTY-07

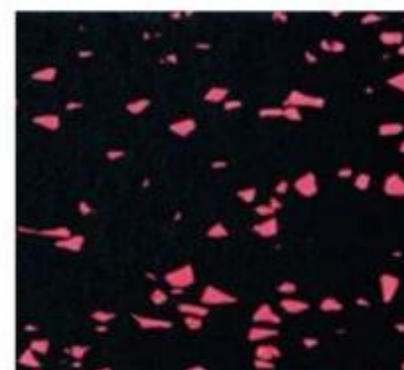

CYTY-08



CYTY-09

复合多彩橡胶地垫

Composite multi-colored rubber floor mats

特点:

Feature

超厚面层 高弹性 易清洁 B2级防火 不易褪色 防潮 无异味 耐老化!

Ultra-thick surface layer, high elasticity, easy to clean, Class B2 fireproof, not easy to fade, moisture-proof, free of peculiar smell and aging-resistant!



平底款
Flat-bottomed style



卡扣款
snap-on splicing style

复合多彩色卡

Composite multicolor cards

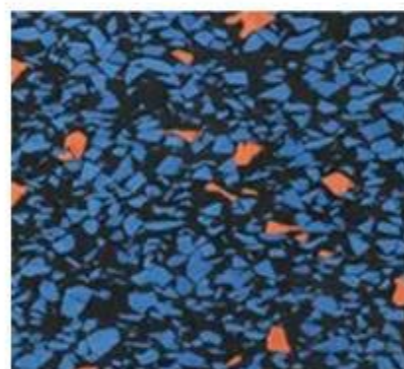

CYTY-10



CYTY-11



CYTY-12



CYTY-13



CYTY-14

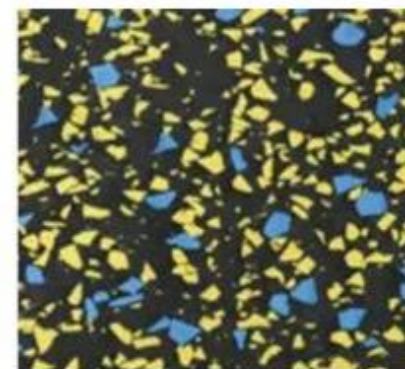

CYTY-15

款式 卡扣拼接款/平底款
style Snap splicing style/Flat bottomed style

长*宽 500*500mm
Length*Width 1000*1000mm

厚度 15mm/20mm
Thickness 25mm/30mm

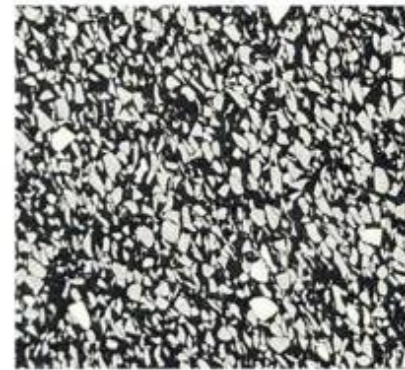

CYTY-16

SPECIFICATIONS

复合橡胶地垫案例展示

Compound rubber mat case show

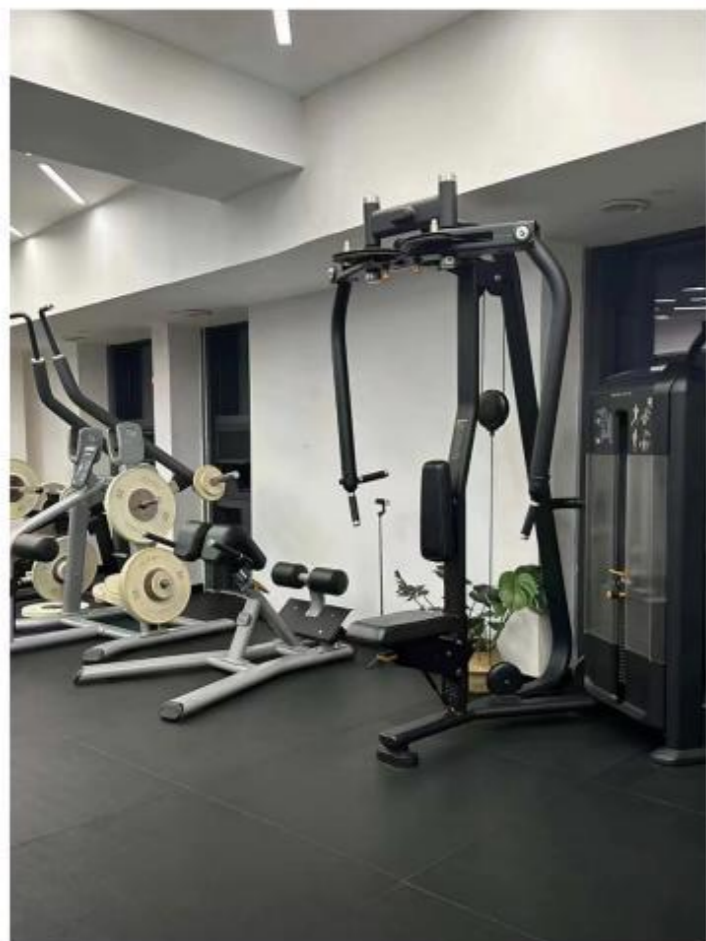

地垫收边条、收边角

Mat edge strip, edge corner



规格: Specifications

长*宽
Length*Width

500*150mm

厚度
Thickness

15mm/20mm/25mm
30mm/35mm

SPECIFICATIONS

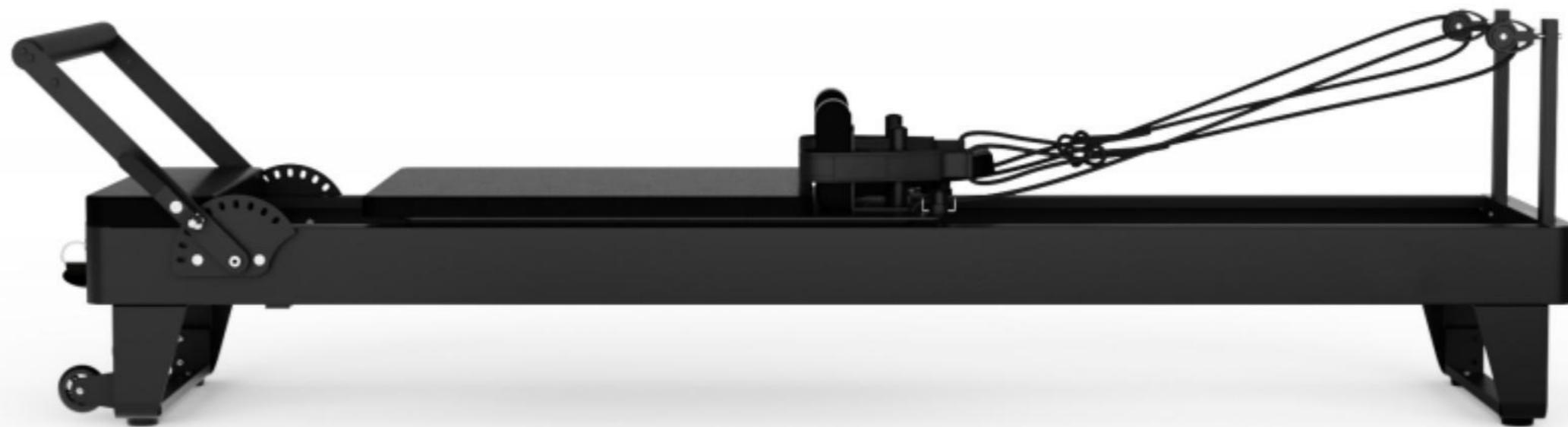

01

Reformer H02

Equipment size: L2360/W600-850/H360
 Equipment weight: 75 kg
 Packaging size&weight: Wooden crate: L2440/W865/H560 149 kg
 Carton: (bed) L2340/W640/H220 75 kg
 (Seating box) L675/W420/H345 15 kg
 Material: Carbon steel/stainless steel/aluminum (different parts have different materials)
 Surface treatment: spray coating
 Safe operating load capacity: 130 kg
 Trolley travel distance: 1075mm
 Adjust the gear lever: 10 gears
 Configuration includes: bed frame/seat box/springboard

Five parameters of the spring (color can be adjusted according to different needs))

Color	Wire diameter mm	Diameter mm	Length mm	Total length mm
Black	2.8	29.8	370	470
Blue	2.3	26.4	370	470
Yellow	2.0	24.7	370	470

Color	Initial force value		Medium term force value		Ultimate force value		Shock times (per thousand)	Punching value	
	KG	LB	KG	LB	KG	LB		KG	LB
Black	3.77	8.33	13.2	29.4	27.8	61.2	100	0.27	0.594
Blue	2.67	5.9	5.7	12.54	14.5	31.9	100	0.16	0.352
Yellow	1.86	4.12	4.22	9.3	8.4	18.6	100	0.11	0.242

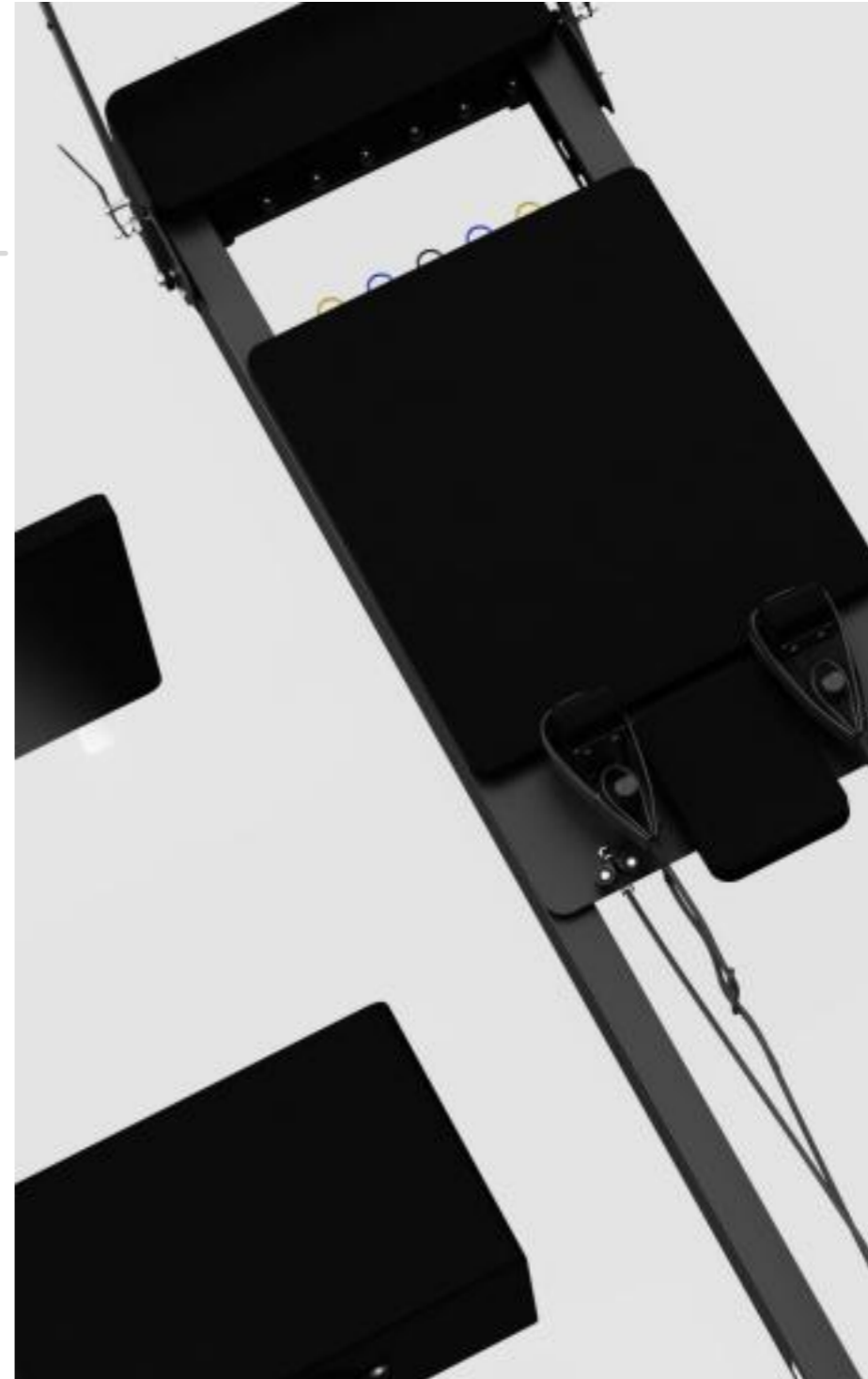

● BLACK

○ GRAY

◐ BLACK & WHITE

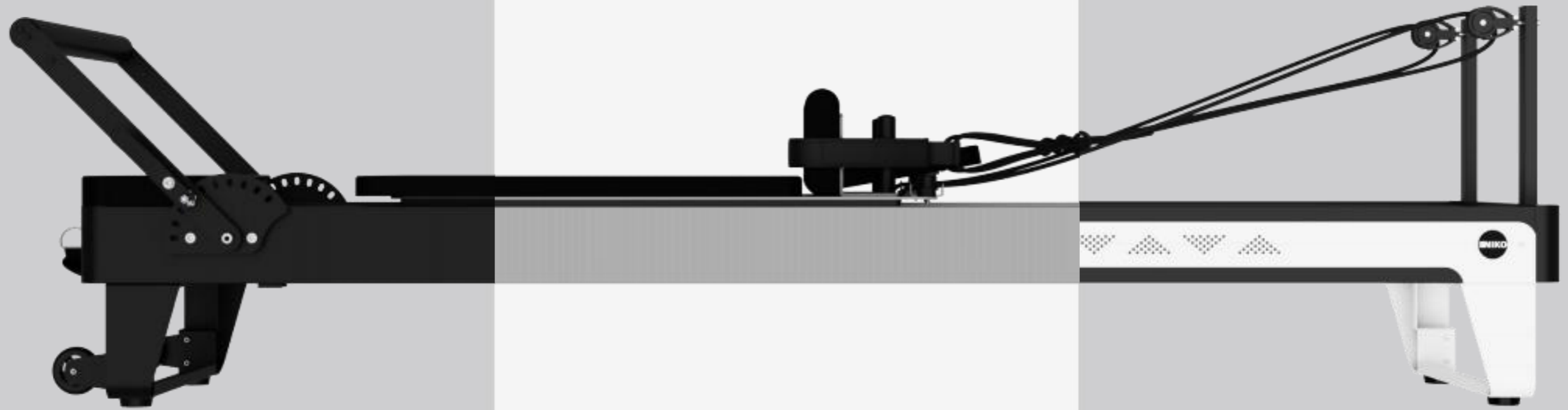

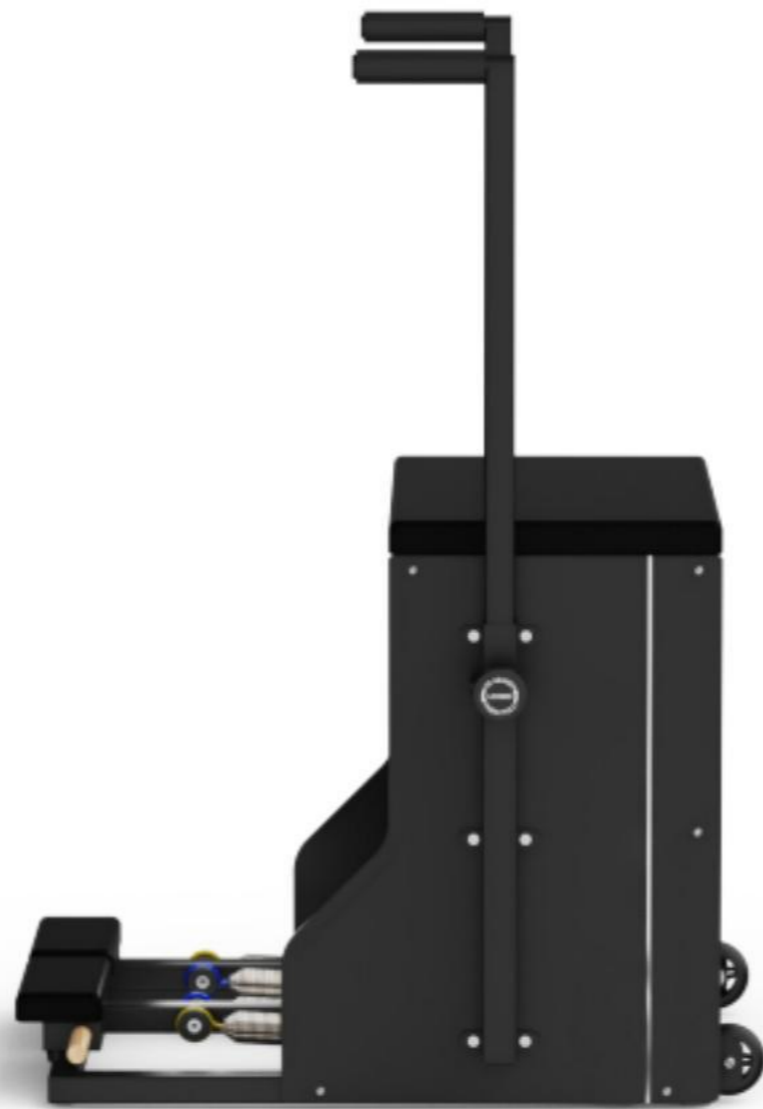

02

Chair W01

Equipment size: L780/W700/H605

Equipment weight: 45 kg

Packaging size&weight:

Wooden crate: L800/W755/H775 63 kg

Carton: (bed) L775/W590/H660 44 kg

(Seating box) L1070/W170/H30 4 kg

Material: Carbon steel

Surface treatment: spray coating

Armrest height adjustment gear: 5th gear

Adjust the gear lever: 3rd gear

Four parameters of the spring:

Color	Wire diameter (MM)	Diameter (MM)	Length (MM)	Total length (MM)
Yellow	3.2	32.1	320	420
Blue	3.5	32.4	320	420

Color	Initial force value		Medium size force value		Ultimate force value		Seating value	Force cutting value	
	KG	LB	KG	LB	KG	LB		KG	LB
Yellow	17.2	37.84	20.3	44.66	28.9	64	70	0.97	2.13
Blue	19.6	43.12	22	48.4	27.7	61	70	0.9	1.98



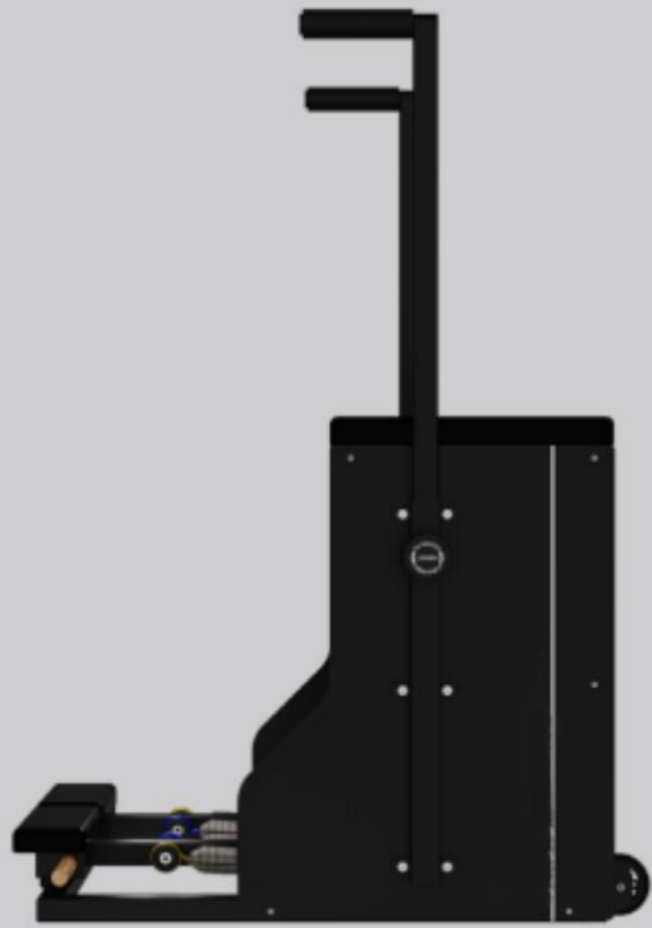

● BLACK

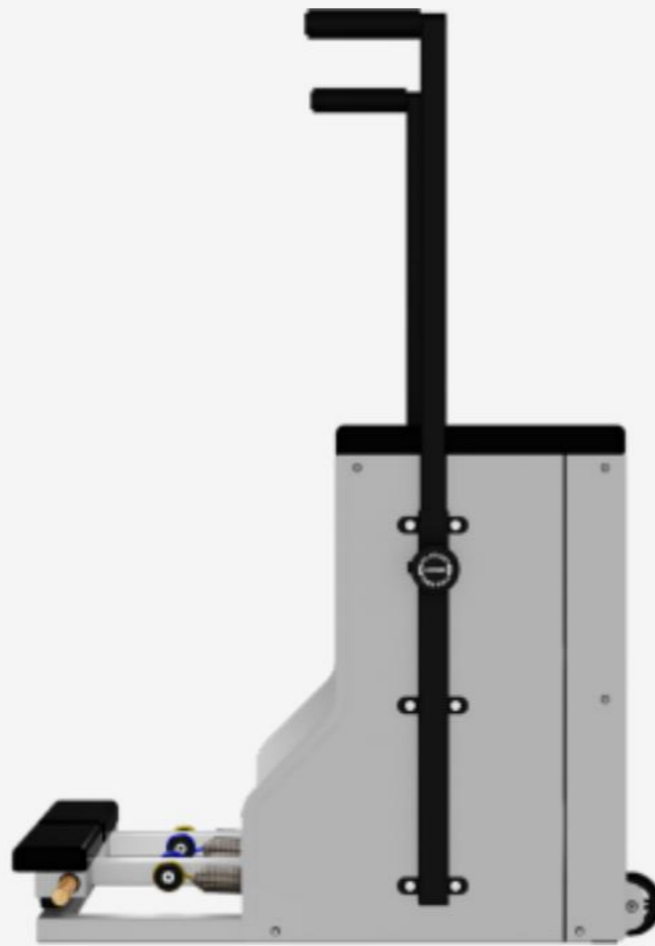

○ GRAY

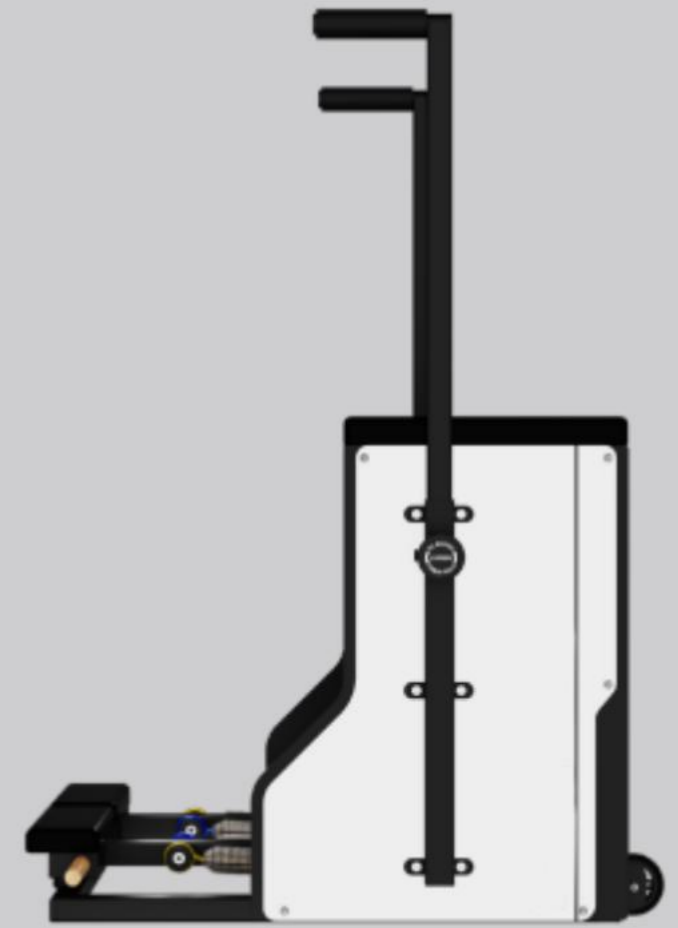

◐ BLACK & WHITE

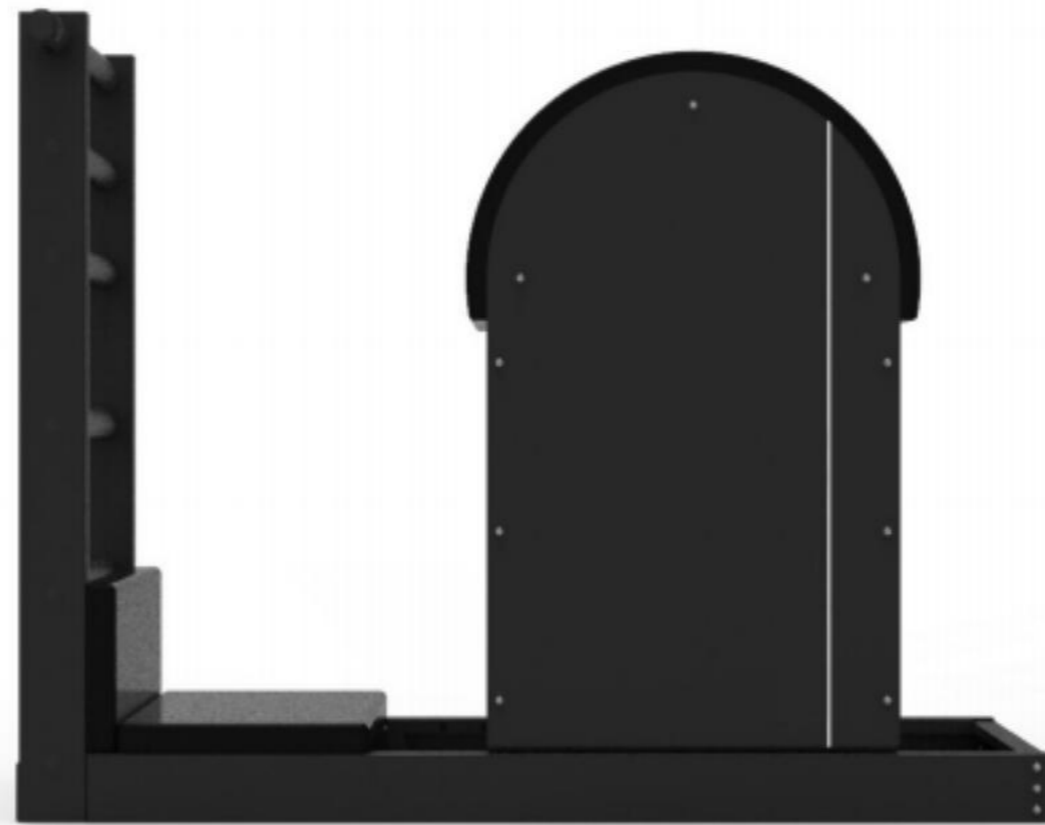

03

Ladder Barrel T02

Equipment size: L1220/W640/H980

Equipment weight: 50 kg

Packaging size&weight:

Wooden crate: L1360/W710/H1115 103 kg

Carton: L1260/W660/H1000 67 kg

Material: Carbon Steel

Surface treatment: spray coating

Bucket level fore and aft adjustment gear: 5

Horizontal circular pipe handle with rubber coating diameter: 42mm





● BLACK

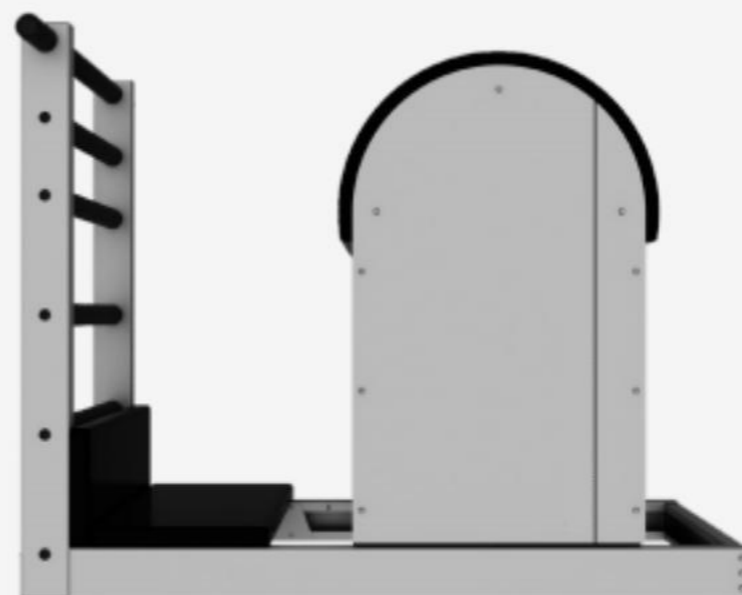

○ GRAY

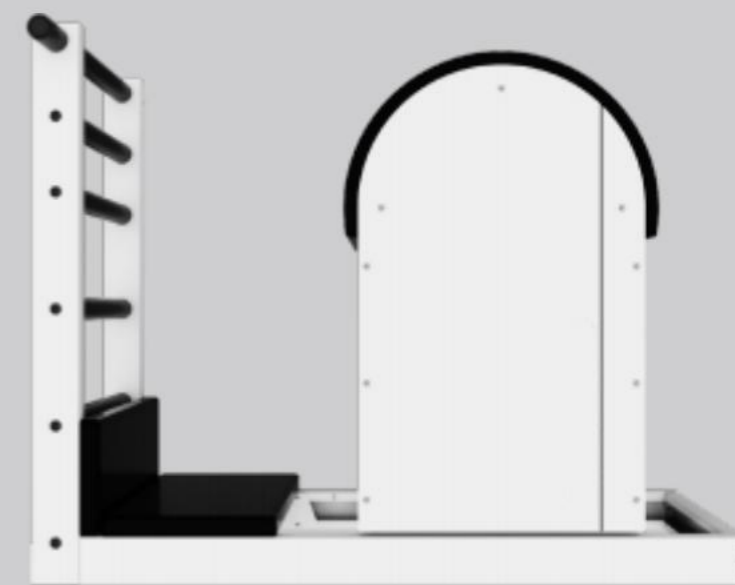

◐ BLACK & WHITE



04

Cadillac K21

Equipment size: L2200/W740/H2030

Equipment weight: 95 kg

Accessories:

German made springs

2 single ring wristbands

1 suspended cushion

Hanging feet with one strap

One safety rope

One round wooden pole

1 side cushion

3mm thick 304 stainless steel round tube

Add spring hook unit

Ten parameters of springs:

颜色	线径(MM)	直径(MM)	长度(MM)	总长(MM)
黄	2.0	24.7	370	470
蓝	2.5	26.8	370	470
黄(长)	2.2	26.5	530	630
蓝(长)	2.5	26.8	530	630
黑	3.5	29.2	270	370

颜色	初始力值		中限力值		极限力值		拉伸次	力阻峰值	
	KG	LB	KG	LB	KG	LB		KG	LB
黄	1.7	3.74	3.6	5.72	11.9	26	70	0.32	0.7
蓝	2.6	5.72	5.73	12.6	13.9	30	70	0.26	0.57
黄(长)	2.7	5.94	6.5	14.3	16.4	36	70	0.17	0.37
蓝(长)	3.98	8.76	6.2	13.64	19.3	42	70	0.19	0.42
黑	19.6	43.12	19.6	43.12	21.3	46.85	70	0.1	0.22





● BLACK

● GRAY

● BLACK & WHITE

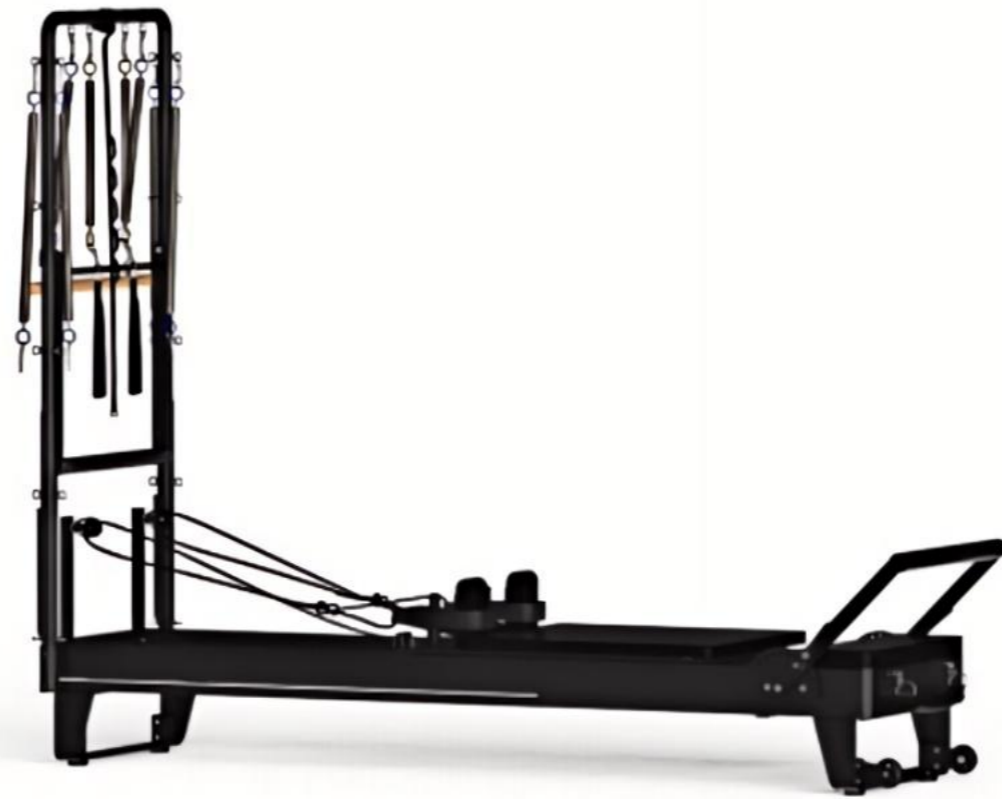

05

Tower H21

Length, width, and height (mm): 2400/600/1685

Weight (kg): 35kg

Accessories:

3mm thick 304 stainless steel round tube or carbon steel metal tube

304 stainless steel tower support

Imported high-density round tube wrapping adhesive

8 springs made in Germany

One large flat leather pad

One round wooden pole

One safety rope

Single ring with 2 pieces

16 304 stainless steel hooks

Eight parameters of springs:

颜色	直径(MM)	直径(MM)	长度(MM)	总长(MM)
黄	2.0	24.7	370	470
蓝	2.5	26.8	370	470
黄(长)	2.2	26.5	530	630
蓝(长)	2.5	26.8	530	630

颜色	初始力值		中期力值		极限力值		拉伸次	力衰减值	
	KG	LB	KG	LB	KG	LB		KG	LB
黄	1.7	3.74	3.6	5.72	11.9	26	70	0.32	0.7
蓝	2.5	5.72	5.73	12.6	13.9	30	70	0.28	0.57
黄(长)	2.7	5.94	6.5	14.3	16.4	36	70	0.17	0.37
蓝(长)	3.98	8.76	8.2	18.04	19.3	42	70	0.19	0.42



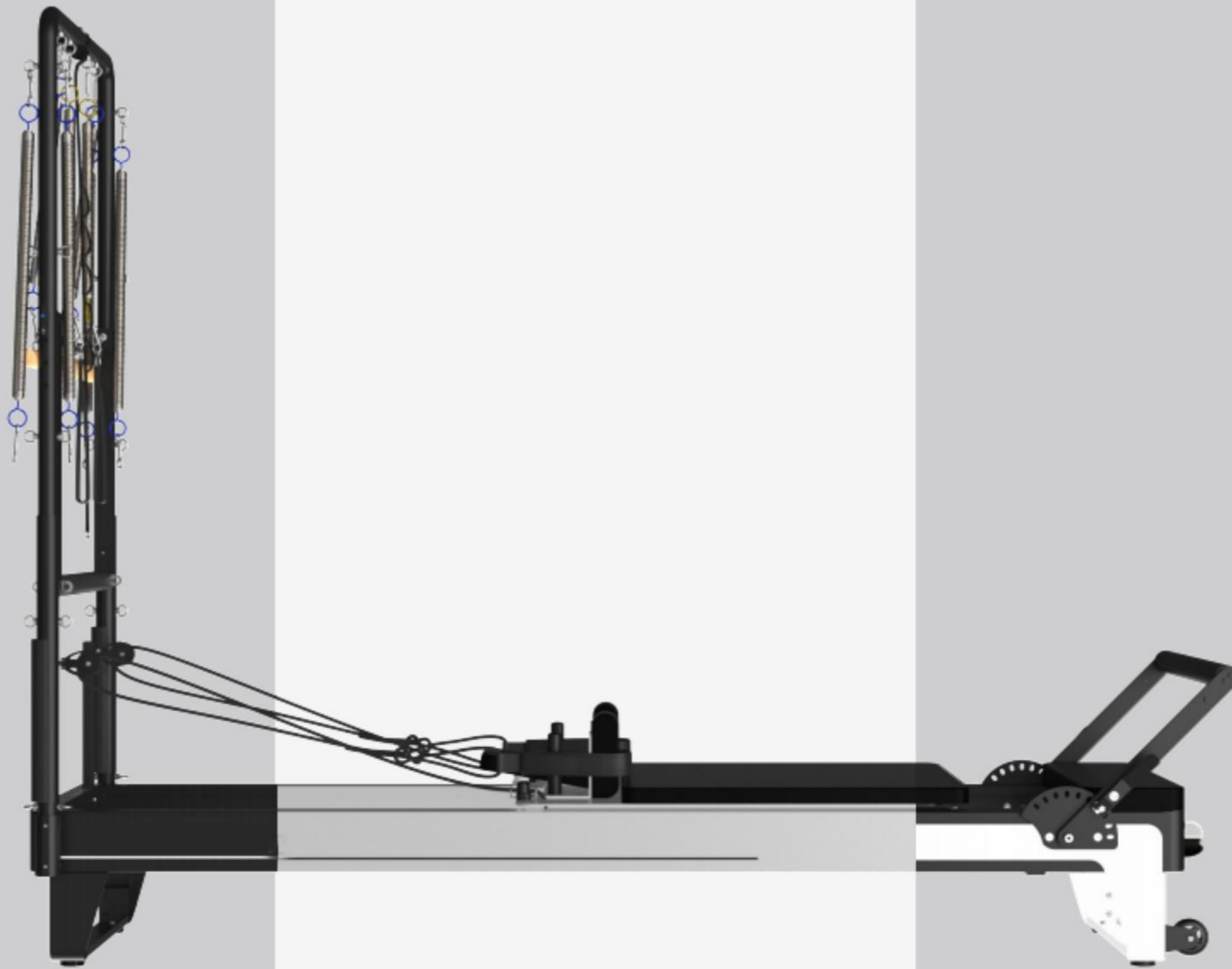

● BLACK

● GRAY

● BLACK & WHITE



06 Spine Corrector J01

Equipment size: L780/W700/H605
Equipment weight: 45 kg





Fully enclosed imported leather provides a comfortable touch and high-quality user experience. High density foam cushioning provides extreme comfort while enhancing proprioception feedback.



01

移动力量 FLEXIBILITY & ADAPTATION

SYNERGIZING YOUR TRAINING PROGRAM

为训练方案带来协同力

高弹药球 MEDICINE BALL

RSPRO0005

Medicine balls, one of the oldest and most versatile fitness tools in history, have been used for centuries to train explosive power and full-body strength, for specific sports training as well as general health training. High-bounce medicine balls have always been classic tools, featuring precise calibration, easy-to-grip rubber texture, and kilogram identification markings, all of which facilitate quick and efficient entry into training.

Number	Specification	Size
RSPRO0005-06	01kg	Ø 19cm
RSPRO0005-01	02kg	Ø 19cm
RSPRO0005-07	03kg	Ø 19cm
RSPRO0005-02	04kg	Ø 23cm
RSPRO0005-08	05kg	Ø 23cm
RSPRO0005-03	06kg	Ø 23cm
RSPRO0005-09	07kg	Ø 28.6cm
RSPRO0005-04	08kg	Ø 28.6cm
RSPRO0005-10	09kg	Ø 28.6cm
RSPRO0005-05	10kg	Ø 28.6cm



地雷沙球 ECHO SLAM BALL

RSPRO0037

Non-elastic and non-bouncing medicine balls, such as sand balls, have become popular equipment for athletes in weightlifting, soccer, wrestling, and martial arts to enhance core strength and explosive power in recent years. Proper use can not only strengthen the back, buttocks, and abdominal muscles (reducing spinal pressure) but also promote stretching of the hips, knees, and ankles, thereby generating greater explosive power. The anti-slip texture on the surface provides good grip even in wet conditions, making it durable and resistant to impact, ensuring it does not burst or leak sand over long-term use. New balls may feel slippery initially but become easier to grip after a few uses; if there is any leakage, standard pumps can be used to inflate them. Note: 3kg and 5kg weights are used for military physical fitness assessments.

Number	Specification	Size
RSPRO0037-01	03kg	Ø 25cm
RSPRO0037-02	05kg	Ø 25cm
RSPRO0037-03	08kg	Ø 25cm
RSPRO0037-04	10kg	Ø 25cm
RSPRO0037-05	12kg	Ø 25cm
RSPRO0037-06	15kg	Ø 25cm
RSPRO0037-07	20kg	Ø 25cm



皮革墙球 WALL BALLA

RSPRO0008

A commonly used training tool that combines various compound movements, including throwing and catching balls, for fun and challenging full-body workouts. It covers multiple planes of motion to enhance functional strength, explosiveness, and muscle stability. The plush filling allows for a better grip, adding functionality to traditional bodyweight exercises. It improves balance and stability, which are essential for injury rehabilitation, through compound movements.

Number	Specification	Size
RSPRO0008-06	03kg	Ø 35cm
RSPRO0008-01	04kg	Ø 35cm
RSPRO0008-07	05kg	Ø 35cm
RSPRO0008-02	06kg	Ø 35cm
RSPRO0008-08	07kg	Ø 35cm
RSPRO0008-03	08kg	Ø 35cm
RSPRO0008-09	09kg	Ø 35cm
RSPRO0008-04	10kg	Ø 35cm
RSPRO0008-05	12kg	Ø 35cm





古老硬式壶铃 HARDSTYLE KETTLEBELL

RSPRO0034

A commonly used training tool that combines various compound movements, including throwing and catching balls, for fun and challenging full-body workouts. It covers multiple planes of motion to improve functional strength, explosiveness, and muscle stability. The plush filling allows for a better grip, enhancing the functionality of traditional bodyweight exercises. It also improves balance and stability, which are essential for injury rehabilitation through compound movements.



Number	color	Specification	Size
RSPRO0034-01		08kg	H30.2 × W14 × Ø21.3cm
RSPRO0034-02		12kg	H30.2 × W14 × Ø21.3cm
RSPRO0034-03		16kg	H30.2 × W14 × Ø21.3cm
RSPRO0034-04		20kg	H30.2 × W14 × Ø21.3cm
RSPRO0034-05		24kg	H30.2 × W14 × Ø21.3cm
RSPRO0034-06		28kg	H30.2 × W14 × Ø21.3cm
RSPRO0034-07		32kg	H30.2 × W14 × Ø21.3cm



经典竞技壶铃 SIGNATURE SPORT KETTLEBELLS

RSPRO0009

Classic kettlebells are made of cast iron with a black powder coating, featuring an ultra-smooth surface that minimizes calluses; ergonomically designed handles offer comfort and biomechanical efficiency; large indented weight numbers and brand logos (in seal script and English) signify Chinese manufacturing, and international standard colors for easy identification. Unlike regular kettlebells, they are configured to meet international competition standards with uniform sizes, which also contributes to the elevated standards of competitive kettlebells.



Number	Color	Specification	Size	Number	Color	Specification	Size
RSPRO0009-01		04kg	H29 × W13 × Ø21cm	RSPRO0009-05		20kg	H29 × W13 × Ø21cm
RSPRO0009-11		06kg	H29 × W13 × Ø21cm	RSPRO0009-06		24kg	H29 × W13 × Ø21cm
RSPRO0009-02		08kg	H29 × W13 × Ø21cm	RSPRO0009-07		28kg	H29 × W13 × Ø21cm
RSPRO0009-12		10kg	H29 × W13 × Ø21cm	RSPRO0009-08		32kg	H29 × W13 × Ø21cm
RSPRO0009-03		12kg	H29 × W13 × Ø21cm	RSPRO0009-09		36kg	H29 × W13 × Ø21cm
RSPRO0009-04		16kg	H29 × W13 × Ø21cm	RSPRO0009-10		40kg	H29 × W13 × Ø21cm



PU壶铃 PU KETTLEBELL

RSPRO0001

The kettlebell has a higher grade, providing a comfortable training experience. It features a stainless steel handle and an environmentally friendly CPU material that is resistant to impact, making it nearly scratch-free even after long-term use. All sizes have uniform specifications, offering a comfortable grip; its unique design, along with prominent weight digits and brand logo, can easily be identified from a distance, making it suitable for professional and stylish individuals or facilities.

Number	Specification	Size
RSPRO0001-01	08kg	H30 × W12 × Ø21.5cm
RSPRO0001-02	12kg	H30 × W12 × Ø21.5cm
RSPRO0001-03	16kg	H30 × W12 × Ø21.5cm
RSPRO0001-04	20kg	H30 × W12 × Ø21.5cm
RSPRO0001-05	24kg	H30 × W12 × Ø21.5cm



皮革壶铃 SOFT KETTLEBELL

RSPRO0003

More friendly for beginners, uniform size makes training experience easier to accumulate. Leather-wrapped rubber particles and iron sand filling ensure that even if it drops, it won't damage the floor or tiles; the sides are reinforced with anti-detachment rivets, and the top is sealed with durable nylon rope; comfortable grip consistent with competition kettlebells; enjoy fun and the convenience of home workouts.

Number	Specification	Size
RSPRO0003-01	06kg	H28 × W13 × Ø21cm
RSPRO0003-02	08kg	H28 × W13 × Ø21cm
RSPRO0003-03	10kg	H28 × W13 × Ø21cm
RSPRO0003-04	12kg	H28 × W13 × Ø21cm
RSPRO0003-05	16kg	H28 × W13 × Ø21cm



3D棒铃 3D CLUBBELL

RSPRO0035

The new upgrade features an updated exterior and internal structure, using TPU material of the same grade as dumbbells to wrap around, reducing collision sounds during use and friction against the skin; it has a smooth knurled handle similar to barbells (depth of 1.5mm), increasing grip friction and safety. Kettlebells are more functional compared to traditional equipment with one-dimensional trajectories, as their training movement paths resemble drawing arcs in three-dimensional space, commonly used for combat strength or comprehensive fitness programs. Lighter kettlebells provide excellent exercise benefits for shoulders, elbows, and wrists, especially significantly improving shoulder joint flexibility and stability.

Number	Specification	Size
RSPRO0035-01	04kg	H55/16.3 × Ø5/2.5cm
RSPRO0035-02	06kg	H55/16.3 × Ø5/2.5cm
RSPRO0035-03	08kg	H61/18.3 × Ø8/3.0cm
RSPRO0035-04	10kg	H61/18.3 × Ø8/3.0cm
RSPRO0035-05	12kg	H66/20.3 × Ø9/3.5cm
RSPRO0035-06	15kg	H66/20.3 × Ø9/3.5cm
RSPRO0035-07	20kg	H74/23.0 × Ø12/4.0cm
RSPRO0035-08	25kg	H74/23.0 × Ø12/4.0cm



机甲手抓片 MECHA-WEIGHT PLATE

RSPRO1005

The mech bell piece has undergone 8,000 drop tests. It features an integrated mech-style icon and is made from a single mold. The handle has a robust cast iron core and a stainless steel middle section, making it rust-resistant and durable. The edges have three widened flat areas that help it stand upright. The indented handle cutout makes it easier to grab and pick up regardless of which side is facing out. A complete set includes six different weight specifications.

Number	Specification	Size
RSPRO1005-01	2.5KG	Ø20.8 × T3cm
RSPRO1005-02	5 KG	Ø28 × T3.3cm
RSPRO1005-03	10KG	Ø32 × T4.2cm
RSPRO1005-04	15KG	Ø37 × T4.4cm
RSPRO1005-05	20KG	Ø42 × T4.6cm
RSPRO1005-05	25KG	Ø45.2 × T4.9cm



机甲直杆杠铃 MECHA-TRAIGHT BARBELL

RSPRO1047

Exclusive design offers a more natural and efficient training experience. The handle is made of alloy steel and coated with durable hard chrome, providing scratch and break resistance. Each solid steel head is precisely calculated, cut, and drilled; high-quality polyurethane is used for precise machining, compression, and securing, resulting in a matte textured surface that is both wear-resistant and impact-resistant. The conspicuous mech style and clear digital markings make these dumbbells easier to identify, ensuring the quality and durability expected by facilities.

Number	Specification	Size	Number	Specification	Size
RSPRO1047-01	10kg	L104 × Ø13.5 × T4.5cm	RSPRO1048-01	10kg	L104 × Ø13.5 × T4.5cm
RSPRO1047-02	15kg	L106.6 × Ø16 × T5.8cm	RSPRO1048-02	15kg	L106.6 × Ø16 × T5.8cm
RSPRO1047-03	20kg	L110.6 × Ø15.8 × T7.8cm	RSPRO1048-03	20kg	L110.6 × Ø15.8 × T7.8cm
RSPRO1047-04	25kg	L110.6 × Ø19 × T7.8cm	RSPRO1048-04	25kg	L110.6 × Ø19 × T7.8cm
RSPRO1047-05	30kg	L112.6 × Ø19 × T8.8cm	RSPRO1048-05	30kg	L112.6 × Ø19 × T8.8cm

机甲曲杆杠铃 MECHA-CURL BARBELL

RSPRO1048



机甲哑铃 MECHA-DUMBBELL

RSPRO1010

This dumbbell represents high-end dumbbells in gyms, catering to different weight specifications for various user needs. This barbell is made of eco-friendly CPU material and has passed an 8000-drop test. Both ends feature a mech-style design, with a one-piece molding that highlights its three-dimensional effect, unlike low-grade rubber wrapping and sticker labeling techniques. The handle is made from heat-treated 45# steel with hard chrome plating on the surface, providing rust resistance and durability.

Number	Specification	Size	Number	Specification	Size
RSPRO1010-01	2.5kg	L24.5 × Ø13 × T4.5cm	RSPRO1010-07	17.5kg	L32 × Ø15 × T8.5cm
RSPRO1010-02	5kg	L24 × Ø13.5 × T4.5cm	RSPRO1010-08	20kg	L30.8 × Ø19 × T7.8cm
RSPRO1010-03	7.5kg	L25 × Ø15.5 × T5.5cm	RSPRO1010-09	22.5kg	L31 × Ø18.5 × T8cm
RSPRO1010-04	10kg	L27 × Ø16 × T5.8cm	RSPRO1010-10	25kg	L33 × Ø19 × T8.8cm
RSPRO1010-05	12.5kg	L28 × Ø16 × T6.3cm	RSPRO1010-11	27.5kg	L34.1 × Ø19 × T9.7cm
RSPRO1010-06	15kg	L30.8 × Ø15.8 × T7.8cm	RSPRO1010-12	30kg	L32 × Ø21.1 × T8.9cm



质心手铃 CENTER MASS BELL

RSPRO0040

Inspired by ancient Chinese lifting art, foot wrestlers, and martial artists, the simplest form of external load for them. By changing the way resistance is held (holding it at the center), higher levels of strength can be developed, making the training path more natural and closely aligned with the kinetic chain, while reducing the risk of injury and meeting dynamic multi-directional goals. It can be used like dumbbells, kettlebells, or medicine balls, incorporating the external load into the kinetic chain so that trainees can practice more compound movement patterns. The design has refined the appearance and weight of the cylinder, ensuring it remains balanced on three planes, while the top and bottom fit together for easy display and storage.

Number	Specification	Color	Size
RSPRO0040-01	06kg	浅蓝	W15 × H15 × T1.1Ø12.5cm
RSPRO0040-02	08kg	粉色	W15 × H15.5 × T1.5Ø12.5cm
RSPRO0040-03	10kg	粉色	W15 × H16.5 × T1.9Ø12.5cm
RSPRO0040-04	14kg	深蓝	W18 × H17 × T2.2Ø12.5cm
RSPRO0040-05	18kg	黄色	W18 × H18 × T2.7Ø12.5cm



方形能量管 FUNCTIONAL TRAINING BARREL

RSPRO0011

The square energy tube is made of eco-friendly rubber material, suitable for family or personal training classes, enhancing communication and fun. It integrates the entire body through three-dimensional plane training, achieving the same effect as strength training, agility training, and balance training. There is no need to change existing training methods; simply incorporate load movements into current training plans using a series of targeted loads to improve physical strength. Traditional energy tubes are cylindrical and small sizes cannot stand upright on the ground, requiring additional purchase of storage racks, which significantly increases costs.

Number	Specification	Size
RSPRO0011-01	04kg	H106 × Ø14.5cm
RSPRO0011-02	06kg	H106 × Ø14.5cm
RSPRO0011-03	08kg	H106 × Ø14.5cm
RSPRO0011-04	10kg	H115 × Ø16.5cm
RSPRO0011-05	12kg	H115 × Ø16.5cm

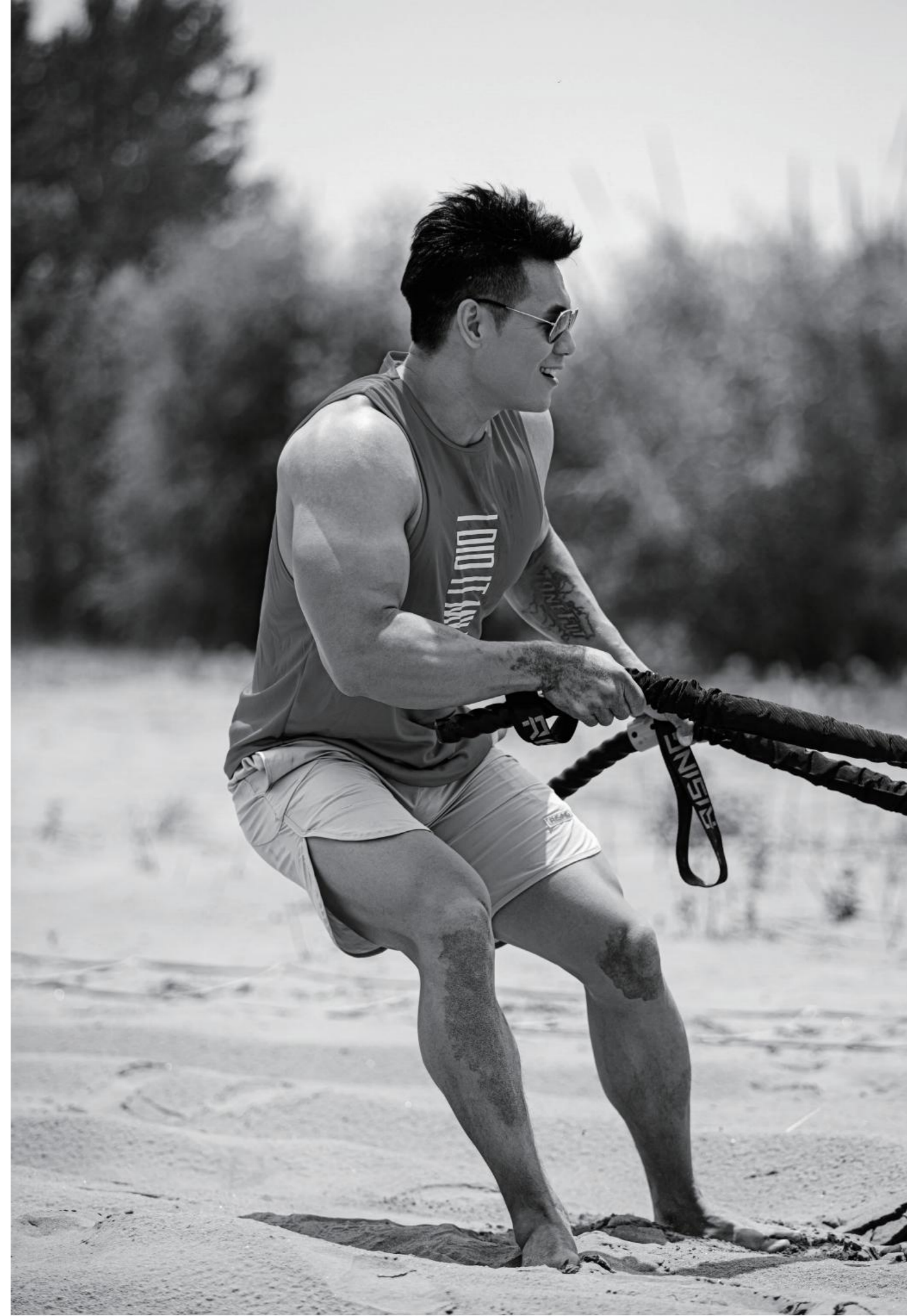



攀爬绳 CLIMBING RDPE

RSPR00021

This climbing strength rope is designed for durability with tightly woven construction, capable of withstanding repeated use and sturdy carabiners. Additionally, to prevent fraying at the ends, we have added extra-thick sealing, elevating physical training to a new level. Note: Inspect for wear before each training session. Dimensions: L600×Ø3.5cm.



格斗战绳-户外款 BATTLE RDPE-DUTDDDR STYLE

RSPR00020

The outdoor combat rope is made of three strands of nylon woven together, featuring sturdy rubber handles and steel rings for secure fastening. The outer dust-proof cover withstands long-term swinging waves; it's an ideal choice for high-intensity interval training and upper body and core exercises. With two lengths available, it meets the needs of both general fitness enthusiasts and athletes, enhancing strength in the shoulders, arms, back, and core.

Number	Specification	Size
RSPR00020-01	基础版	L1200×Ø3.5cm
RSPR00020-02	专业版	L1500×Ø3.5cm



RSPR00023

Indoor battle ropes feature significant 'wave' motion performance and are made from soft, densely woven material, greatly increasing their durability and preventing the rope from loosening. The sealed handle with a steel ring helps prevent the rope from slipping out of your hands. The ropes come in two different lengths: 12 meters and 15 meters. The longer the rope, the more challenging it is to start. The 12-meter length is the most common for cross-training and HIIT workouts.

Number	Specification	Size
RSPR00023-01	基础版	L1200×Ø3.5cm
RSPR00023-02	专业版	L1500×Ø3.5cm



网 铝合金跳绳 SPEED JUMP RDPE

RSPR00042

With its unique self-locking design, the rope can be adjusted to the desired length in just seconds. The latest speed jump rope features a high dual-arm system, specifically designed for serious athletes, with built-in bearings providing 360-degree rotation. The cross jump rope is made of steel wire coated with wear-resistant PVC, ensuring durability, smoothness, and preventing cracking or breaking.

Dimensions: Rope L280×0.3cm, Handle L16.5×1.6cm.



负重跳绳 WEIGHTED JUMP RPE

FRSPR00022

The tightly woven rope body, combined with an ergonomically designed rubber-coated anti-slip handle, comprehensively enhances physical fitness levels. In reality, lighter ropes are harder to control during movement, while weighted jump ropes slow down the rotation speed of the rope, thereby increasing sufficient resistance, which better coordinates the entire body and engages more muscle groups.



木质吊环 HAND RINB

RSPR00036

The rings were introduced to the Olympics in 1908 and have since been an important event, serving as equipment for testing and training upper body and core strength. Wood is chosen for its durability and functional standards; it can better secure magnesium powder, providing a better grip surface that makes complex movements easier to execute. The steel reverse lock allows for easy adjustment, while the embroidery on the strap enables quick height adjustment between the two rings, solving the traditional cumbersome adjustment problem of the CF BOX high-end gym's straps (maximum hanging height of 2.3 meters). Dimensions: ring outer diameter 23.5 cm / grip width 3.2 cm. Strap dimensions: L 250 cm × W 3.8 cm.



NEW 旋转训练系统 ROTATIONAL TRAINING SYSTEM

RSPRO0041

Drawing experience from a wide range of bodyweight training bands, focus on diagonal training concepts, and elevate bodyweight training to a new level through pulley-based static and rotational exercises. When the rope bypasses the pulley, RTS functions like traditional bands and can easily adjust its height. When the single rope slides, RTS becomes a dynamic training system, allowing for significant rotational movements. Achieve balance by working out at all angles (kinetic chain) to build rotational and counter-rotational core stability, which means more bodily functions can be unlocked, enhancing overall strength and endurance.

The steel wire attachments:

RTS can not only withstand rigorous self-weight training but also 'lift weights equivalent to its own body weight'. The pulley is connected to the cable machine to perform actions such as 'wood chopping' or 'single-arm punch', while strengthening arms and legs through diagonal resistance lines.

The sleigh attachment:

RTS can be installed on the sleigh to provide towing/harness straps that target the lower limbs at different angles, while the pulley system enhances anti-rotation capabilities, allowing for maximum strength and endurance of the lower body without affecting the lower back and spine.

Static pull test: 350 kg,
Wear-resistant rope: L200 cm,
Adjustable strap: L90-150 cm.



梯形踏板 AEROBIC STEP

RSPRO0027

Reinforced design using resilient engineering materials, with thick rubber non-slip surface and base for safety and stability; spacious platform suitable for various aerobic classes; three height adjustments (15/20/25 cm) to target different training goals. Ideal choice for home use, group classes, or personal training sessions.

Dimensions: Platform L103.5×W37.5×H25.5 cm

Base W60×H20 cm



八角形踏板 OCTAGONAL AEROBIC STEP

RSPRO0025

Made from heavy-duty injection-molded plastic, it is lightweight and portable, ensuring easy storage when not in use. It is an ideal choice for aerobic exercise and physical training, but can also be used for weight training and bodyweight exercises.

Dimensions: Panel 40x8cm x 1 piece,
Base 40x5cm x 2 pieces.



训练百宝箱 ADJUSTABLE MULTI-FUNCTIONAL DUMBBELL TRAINING BOX

RSPRO0029

A design that perfectly combines functionality and creativity, accelerating conversion speed and enhancing safety, all-in-one storage equipment. It makes the training area look neater and more organized. Besides its excellent storage function, it is also an extremely creative fitness bench, capable of performing over 200 full-body exercises such as sitting, stepping, and securing other equipment. The storage space can accommodate other functional training equipment like medicine balls, resistance bands, jump ropes, kettlebells, sandbells, etc. Suitable for home office relaxation areas, group classes, and other venues. The heavy training box can be easily moved using wheels. Note: Does not include listed products; additional configuration required. Dimensions: L132×W36×H52cm.



轮胎翻滚器 TYRE FLIP MACHINE

RSPRO0032

The design features rolling flexibility and low noise, with solid construction materials. It comes with an anti-slip safety base for stability and pressure resistance, occupying only the space of one tire, allowing you to enjoy 360-degree tire flipping exercises. Suitable for indoor training venues and personal training areas on floors.

Note: The tire includes a weight plate holder inside.

Dimensions: W145×D120×H55cm

Weight: 110kg



十角轮胎 DECAGONAL TRAINING TIRE

RSPRO0033

The ten-sided tire includes all elements of functional training tires, with convenient hand grips that are easy to hold. The tire is suitable for both indoor and outdoor use, allowing for various strength and interval exercises. Use the tire for flips, weightlifting, farmer's walks, jumps, and more! The built-in recycled sponge prevents accidental pressure and collisions during training, and the leather cover makes it easy to wipe down after each use. The three-dimensional cut ensures it doesn't roll or collapse when upright. Note: All three sizes are consistent, but they contain different ratios of dust-free iron sand.

Number	Specification	Size
RSPRO0033-01	60kg	内Ø60cm 外Ø120cm
RSPRO0033-02	80kg	内Ø60cm 外Ø120cm
RSPRO0033-03	100kg	内Ø60cm 外Ø120cm



重训雪橇车 HEAVY STRENGTH SLED

RSPRO0030

The sled is designed to withstand a series of intense workouts. From pushing, pulling, speed, and interval training, this sled covers the entire training session. The hooks allow for attaching ropes or other accessories, adding more challenges to the body; the central bar can hold up to 10 weight plates for intense full-body exercises, targeting leg, core, arm, shoulder, and exploratory training.

Dimensions: L67×W96×H58cm, bar length 40cm, handle width 5cm.

Weight: 30kg.



磁控坦克车 TANK SLED MACHINE

RSPRO0031

As an outdoor fitness training tool developed by Rise, it features eight-level magnetic resistance adjustment, commercial chain drive, widened wheels, and durable extended handles. It significantly enhances performance metrics and promotes personal trainer conversions. As the designated product for physical challenge events, this tank push cart has been widely used in various venues. Note: Transported in wooden crates, includes storage frame.

Dimensions: L120×W72×H108cm,

Wheel diameter: 29cm,

Weight: 70kg.



牛角训练包 STRENGTH TRAINING BAG

RSPRO0010

Kettlebells, also known as Bulgarian bags, can be used to strengthen the upper body, abdominal muscles, and the entire muscular system. These bags can be swung, thrown, gripped, and lifted, or used for traditional sit-ups. Kettlebells offer comprehensive functionality thanks to their five integrated handles, nylon rings, grips, and semi-circular shape. New movements can be intuitively designed to add fun to training, making kettlebells an ideal choice for both group and individual workouts.

Number	Specification	Size
RSPRO0010-01	04kg	L65×W55cm
RSPRO0010-02	06kg	L65×W55cm
RSPRO0010-03	08kg	L65×W55cm
RSPRO0010-04	10kg	L65×W55cm
RSPRO0010-06	12kg	L65×W55cm
RSPRO0010-05	16kg	L65×W55cm
RSPRO0010-07	20kg	L65×W55cm



六角沙饼 SAND BELL

RSPRO0016

The Hexagon Sand Cake is made from thick composite waterproof fabric, featuring a dynamic grip design that combines the best functions of dumbbells, kettlebells, medicine balls, sliders, and sandbags... challenging stable muscles and enhancing core endurance. The flowing sand provides a unique training effect for instability and also challenges grip strength for wrists and forearms. Its hexagonal shape with bright yellow numbering and built-in dust-free iron sand is suitable for traditional free weight, catching, throwing, and explosive power movements both indoors and outdoors.

Number	Specification	Size
RSPRO0016-01	02kg	020cm
RSPRO0016-02	04kg	023cm
RSPRO0016-03	06kg	026cm
RSPRO0016-04	08kg	029cm
RSPRO0016-05	10kg	②31cm



巨石沙袋 STRONGMAN BAG

RSPRO0006

The design inspiration comes from Icelandic lifting stones, and the sandbags come in three sizes, made of high-strength material with double stitching. The back and sides have fabric handles, with an internal waterproof flap folded into a zipper closure, and an external Velcro cover for triple waterproofing. Since the sandbag can be emptied, it can be refilled at places like gyms, fields, beaches, and parks, making it very portable. Note: There is a mesh channel inside connecting the front and back; capacity and weight depend on the density and size of the filling medium. Attention: This product is an empty bag without weights.

Number	Specification	Size
RSPRO0006-01	容量 40 k g	L55×W45×H20cm
RSPRO0006-02	容量 60 k g	L55×W50×H20cm
RSPRO0006-03	容量 80 k g	L65×W60×H20cm



团体沙袋 TEAM WORM BAG

RSPRO0015

The use of group sandbags is similar to that of log drills for troops. Carrying log drills can enhance team cooperation awareness. When daily training involves frequent repetition, it may cause skin abrasion injuries. Therefore, the eco-friendly and flexible material of group sandbags provides protective benefits. They also feature personalized designs that better suit actual usage, with tight stitching that resists cracking; durable Velcro combined with zippers for double sealing.

Number	Specification	Size
RSPRO0015-01	60kg/2-4人	L200×030cm
RSPRO0015-02	90kg/3-5人	L300×030cm
RSPRO0015-03	120kg/4-6人	L400×030cm



固定能量包 POWER BAG

RSPRO0012

The fixed energy packs use heavy-duty nylon straps, thick outer layers, and easily identifiable weight numbers for advanced selection. For those looking to change their fitness habits, using training packs can enhance dynamic, compound, and rotational movements to improve functional strength, range of motion, and explosiveness. Utilize multi-directional movements to increase movement variety and often overlooked stabilizer muscles, which helps prevent injuries and strengthen grip, key factors in lifting heavier weights.

Number	Specification	Size
RSPRO0012-01	04kg	L55x022cm
RSPRO0012-02	06kg	L55x022cm
RSPRO0012-03	08kg	L55x022cm
RSPRO0012-04	10kg	L55x022cm
RSPRO0012-05	16kg	L55x022cm
RSPRO0012-06	12kg	L55x022cm
RSPRO0012-07	20kg	L55x022cm
RSPRO0012-08	25kg	L55x022cm
RSPRO0012-09	40kg	L55x022cm



可调节能量包 ADJUSTABLE POWER BAG

RSPRO0014

Adjustable energy bags are perfect for group training and teaching complex compound movements while also strengthening stabilizer muscles. The sandbag has a durable outer fabric layer and is self-filling with sand, making it versatile. The robust handles of all sizes make the bags add extra challenge. The bags can be easily emptied and refilled for different scenarios. Note: This product comes empty and does not include weights; recommended fillers include soil or fine sand.

Number	Specification	Size
RSPRO0014-01	容量20kg	L60×022cm
RSPRO0014-02	容量40kg	L70×025cm

可调节水袋 ADJUSTABLE AQUA BAG

RSPRO0043

When water flows inside the bag, the weight constantly shifts, making core muscles react and engage at an entirely new level. By forcing the body to resist and control the unpredictable movement of the water, it provides a unique challenge for joints and stabilizing muscles. The weight of the water bag is fully adjustable, depending on how much water is added or removed; the maximum capacity is 20 kilograms. Three different grip options make the water bag more versatile. Material: PVC mesh fabric. Size: L75×20cm.



钢沙软管 STEELHOSE

RSPRO0038

The hose, based on different lengths/diameters and weights, provides stability and continuous flow by adding appropriate resistance through grip positions that change the lever pivot and hanging holes with unique links, achieving new proprioceptive movement. Weighing between 2.5-10 kg, even when maintaining static postures, the structure of the hose continues to change in the hands and body, thereby establishing proprioception and hand-eye coordination within the body. Weighing between 2.5 kg, unlike all other bags, it creates instability through semi-rigid fixation, flowing within a fully controllable range and constantly absorbing grip force as the movement speed changes, promoting control and transition between simple and complex movements (handle suitable for rotational and pulling motions). 2.5-10 kg handle-free: suitable for dynamic aerobic exercises, mobility, yoga/Pilates. 15-25 kg with handle: suitable for flow patterns, partner exercises, strength training, high-intensity workouts.

Number	Specification	Dimensions
RSPRO0038-01	2.5kg	L50×05cm
RSPRO0038-02	05kg	L60×05.5cm
RSPRO0038-03	10kg	L70×07.55cm
RSPRO0038-04	15kg	L80×08.5cm
RSPRO0038-05	20kg	L90×011cm
RSPRO0038-06	25kg	L100×012cm



举重配重片 FRACTIONAL PLATE

RSPRO1001

When training pushes beyond limits and strives for achievement, every kilogram matters. Here are five weight increment specifications: all plates ensure uniform hole diameter, compatible with any standard Olympic barbell, and a unified color design creates a cohesive appearance when adding plates. The high-quality matte surface and raised logo and numbers make the plates bold and easier to identify from a distance. Weights: 0.5KG, 1KG, 1.5KG, 2KG, 2.5KG

Number	Specification	Color	Size
RSPRO1001-01	0.5KG		Ø13.5×T1.5cm
RSPRO1001-02	1.0KG		Ø16.5×T1.6cm
RSPRO1001-03	1.5KG		Ø16.6×T2cm
RSPRO1001-04	2.0KG		Ø19×T2.2cm
RSPRO1001-05	2.5KG		Ø21×T2.2cm



聚氨酯竞技片 COMPETITION BUMPER PLATES

RSPRO1002

Polyurethane competition plates are made from high-quality and high-hardness polyurethane, featuring durable and easily identifiable colored bodies that produce consistent dead drops upon long-term impacts while maintaining their shape. To combine performance and durability, each plate features a hard-chrome steel disc design to minimize friction on the sleeves. Each plate has black branding and gray numbered markings (gray on black plates), which are raised and color-coded for

Number	Specification	Color	Size
RSPRO1002-01	5KG		Ø45×T2.7cm
RSPRO1002-02	10KG		Ø45×T3.7cm
RSPRO1002-03	15KG		Ø45×T4.5cm
RSPRO1002-04	20KG		Ø45×T5.2cm
RSPRO1002-05	25KG		Ø45×T5.7cm



经典铸铁片 CAST IRON WEIGHT PLATE

RSPRO1004

Nothing is more interesting than replicating pure old-school training. Classic steel plates are the gold standard for seeking the essence of training, and time-tested cast iron plates have higher precision than many similar products in the industry. High-quality processing makes them simple, classic, and robust enough for daily use.

Weight options: 2.5KG, 5KG, 10KG, 15KG, 20KG.

Material: Cast iron.

Number	Specification	Size
RSPRO1004-01	2.5KG	Ø20×T2cm
RSPRO1004-02	5KG	Ø25×T2.5cm
RSPRO1004-03	10KG	Ø38×T2.7cm
RSPRO1004-04	15KG	Ø40×T3.6cm
RSPRO1004-05	20KG	Ø42.5×T4cm



六角小哑铃 RUBBER HEX DUMBBELL WITH BLACK HANDLES

RSPRO1007

The hexagonal small dumbbell uses high-quality, durable, and wear-resistant rubber coating; with a black finish and yellow accents, it offers a classic and vibrant combination that looks great in any setting; its textured handle design features modern aesthetics, replacing old-fashioned steel blocks with a smooth and eye-catching alternative; the brand's reliability remains consistent, making it perfect for home or commercial gyms and studios. Weight: 1KG—10KG (1KG increments)

Number	Specification	Size	Number	Specification	Size
RSPRO1007-01	1kg	L19.3×Ø6.7×T3cm	RSPRO1007-06	6kg	L26.5×Ø10.5×T6.8cm
RSPRO1007-02	2kg	L21.2×Ø8×T4cm	RSPRO1007-07	7kg	L27×Ø11.3×T6.8cm
RSPRO1007-03	3kg	L23×Ø9×T5cm	RSPRO1007-08	8kg	L27.5×Ø12.3×T7cm
RSPRO1007-04	4kg	L24.6×Ø9.5×T5.8cm	RSPRO1007-09	9kg	L28×Ø12.8×T7.2cm
RSPRO1007-05	5kg	L25.2×Ø10×T6.2cm	RSPRO1007-10	10kg	L30.4×Ø12.8×T8.5cm



NEW 实心软球 MEDICINE BALL

RSPRO9017

The unique surface design of this ball provides twice the friction compared to standard leather balls. The solid leather ball offers a unique combination of functionality and durability. Available in two sizes, 25 cm and 30 cm in diameter, it features weight specifications achieved through iron sand/rubber particles. The outer layer consists of 18 durable leather panels and is stitched with 7 cm of 4-thread seams. It is commonly used for explosive strength training, particularly for high throws and spinning throws, making it a reliable addition for high-intensity specialized training and women's fitness.

Number	Specification	Size
RSPRO9017-01	1kg-绿	025cm
RSPRO9017-02	2kg-绿	025cm
RSPRO9017-03	3kg-黄	025cm
RSPRO9017-04	4kg-黄	⑦25cm
RSPRO9017-05	5kg-蓝	030cm
RSPRO9017-06	6kg-蓝	030cm
RSPRO9017-07	7kg-红	030cm
RSPRO9017-08	8kg-红	030cm



NEW 悬挂训练系统3.0 SUSPENSION TRAINING SYSTEM 3.0

RSPRO9006

STS is a training system that shapes and strengthens the body using its own weight. Resistance can be increased or decreased by changing the angle. Upgraded to version 3.0 after testing by fitness trainers, it is designed for extensive strength, aerobic, and mobility training anywhere. 1. Replace anti-friction handles and minimalist adjustment clips; 2. Upgrade foot straps to Velcro-adjustable ones; 3. Add door anchor and extended connection strap. Note: Inspect wear and tear carefully before each workout. Size: Adjustable up to 380 cm long.



NEW 拥抱支撑架 PUSHUP HUG RACK

RSPRO9014

Magnetic lock mechanism and foldable solid wood frame, unique design easily fits into luggage or can be stored at home. Anti-slip pads provide ergonomic grip and stability for exercises of various body weights, enhancing shoulder stability, balance, and strength. Suitable for unlocking new skills: L-shaped and V-shaped postures, push-ups, handstands, gymnastics, etc., to train triceps, biceps, chest muscles, deltoids, core muscles, etc. Patent pending.

Number	Specification	Size
RSPRO9014-01	MIN款/1kg	L30×H10.3×O3.7cm
RSPRO9014-02	PRO款/1.5kg	L50×H13.5×O3.7cm

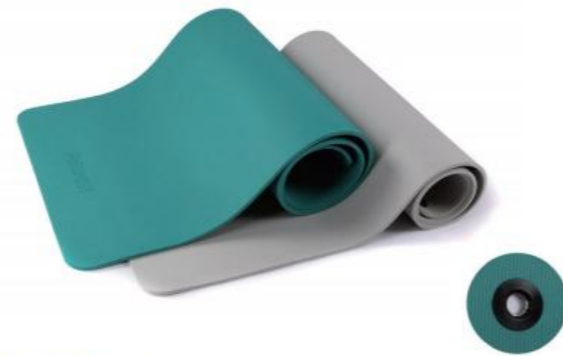

NEW 私教挂垫 PERSONAL TRAINER HANGING MAT

RSPRO9011

Select eco-friendly TPE-A grade material (thermoplastic elastomer) for production, which has minimal environmental impact and is recyclable. It provides stable grip in both dry and wet conditions, which is crucial for maintaining posture stability and preventing slips. The soft 8mm thickness is particularly suitable for beginners or customers with sensitive joints; its length of 1.73 meters not only prevents customers from stepping on it but also offers convenient working conditions for trainers. Note: Hole spacing is 48 cm.

Number	Specification	Size
RSPRO9011-01	绿色	L173×W61×T0.8cm
RSPRO9011-02	灰色	L173×W61×T0.8cm



NEW 足趾功能板 TOE FUNCTION BOARD

RSPRO9015

An innovative balance board designed to enhance foot stability for improved health, targeting and reshaping the intrinsic functional structure of the lower limbs. By integrating musculoskeletal anatomy and lower limb biomechanics theories, it ensures that the foot and balance board work as a whole, establishing consistency between the foot, hips, and core to prevent injuries and boost performance in sports. The design allows separate use for either the left or right foot, featuring two detachable fin pieces (for adjusting incline) to achieve all necessary foot mobility, stability, and strength.

可持续塑造无限可能性
WITH SUSTAINABLE CREATING INFINITE POSSIBILITIES

一个有意识的软木瑜伽系列，旨在传达正念和对自然的深刻尊重。软木是由专业人员在不对树干造成损害的情况下可持续采集，它是一种天然材料，既可再生又可回收。1立方厘米的软木约含有4000万个细胞，软木因其肺泡结构而被称为“大自然的泡沫”。创新和工程团队将软木与其他材料结合，配方中含有100%天然和可回收的材料，保证其应用所需的性能。

A CORK-BASED YOGA COLLECTION WITH CONSCIOUS AIMS TO CONVEY MINDFULNESS AND PROFOUND RESPECT FOR NATURE. CORK IS HARVESTED BY PROFESSIONALS WITHOUT DAMAGING THE TRUNK. IT IS NATURAL, SUSTAINABLE AND RECYCLABLE. CORK IS KNOWN AS "NATURE'S FOAM" DUE TO ITS ALVEOLAR STRUCTURE, WITH EACH CUBIC CENTIMETER OF CONTAINS 40 MILLION CELLS. COMBINED WITH OTHER MATERIAL BY INNOVATORS AND TECHNICIANS, CORK SERIES, CONTAINING 100% PURE NATURAL AND SUSTAINABLE MATERIAL, IS ASSURED TO PERFORM WELL IN ALL APPLICATION.



NEW 瑜伽垫-软木 CORK YOGA MAT

RSPRO9030

Designed for long-lasting use, the underside features high-density rubber for secure grip and additional stability during yoga practice. The surface is made of fine cork particles with anti-slip properties and skin-friendly characteristics. Both men and women can fully utilize their potential on the yoga mat.

Cleaning: Simply wipe clean with a damp cloth (no chemicals needed) and let it air dry. Dimensions: L183×W61×T0.5cm



NEW 冥想垫-软木 CORK MEDITATION MAT

RSPRO9029

Natural cork surface layer, soft and comfortable to sit on, designed for quick entry into meditation; the bottom is made of natural rubber, providing excellent grip. A 5mm high-density circular mat that can be widely used for yoga, meditation, relaxation, or placed in the living room for children to play on. Additionally, it can also serve as a Pilates mat, dance mat, or outdoor camping mat. This mat can fulfill different needs depending on the situation.

Cleaning: Just wipe clean with a damp cloth (no chemicals needed), then air dry. Dimensions: 60x0.5cm



按摩球-软木 CORK MASSAGE BALL

RSPRO9021

Designed specifically for adult muscle relaxation massage, this fascia ball is four times lighter than similar rubber balls and is not intended as a toy or bouncy ball for children. It helps release muscle knots through self-myofascial release and moisturizes the fascia to alleviate pain and stress. When used alongside exercise, it can increase strength and flexibility.

Cleaning: Simply wipe clean with a damp cloth (no chemicals needed) and allow to air dry.

Size: 8cm



花生球-软木 CORK PEANUT MASSAGE BALL

RSPRO9022

The peanut-shaped double-headed ball is smooth and sturdy, making it a portable solution for pain relief and relaxation. Whether you're anywhere, you can use its own weight to relieve muscle knots and tension, or incorporate it into your training routine before, during, or after exercise to enhance benefits. Cleaning: Just wipe clean with a damp cloth (no chemicals needed) and let it air dry.

Dimensions: L16×08cm



护膝垫-软木 CORK EXTRA CUSHION

RSPRO9028

The knee pads remain flat without curling edges, specifically designed for support and durability of the knees, wrists, and elbows. Whether used alone or with a cork yoga mat, the non-slip surface ensures stability for each pose. The thick knee pads provide pain-free and comfortable support throughout the entire practice.

Cleaning: Simply wipe clean with a damp cloth (no chemicals needed), then air dry. Size: L61×W25×T2.5cm



斜坡板-软木 CORK YOGA WEDGE

RSPRO9027

The slant board is a yoga prop designed with a slope that aligns well with the body's physiological structure, supporting yoga practices from heel to hand. It is particularly suitable for Iyengar, Anusara, and restorative yoga. Made of natural cork, it features rounded edges, a non-slip surface, sweat resistance, a soft exterior, and is unlikely to peel or crack easily.

Cleaning: Simply wipe clean with a damp cloth (no chemicals needed) and let it air dry.

Dimensions: L61×W11×T14cm



瑜伽砖-软木 CORK YOGA BLOCK

RSPRO9024

A must-have tool for practitioners of all levels of yoga, the brick's comfortable grip and sturdy structure make practice feel safer. Its rounded edges and textured surface offer excellent fit and control during challenging poses. Shorten or deepen stretches for optimal positioning. Suitable for yoga meditation, recovery, Pilates, and various other fitness and exercise routines. Cleaning: Simply wipe clean with a damp cloth (no chemicals needed), then air dry.

Dimensions: L22.8×W15×H7.6cm



鸡蛋砖-软木 CORK EGG BLOCK

RSPRO9023

Egg-shaped yoga blocks bend to fit the contours of the body, featuring ergonomic curves, rounded edges, and a non-slip, moisture-absorbing surface. They are particularly useful for side-lying poses and backbends. Cleaning: Simply wipe clean with a damp cloth (no chemicals needed) and let air dry.

Dimensions: L30×W12×H7.5cm.



瑜伽轮-软木 CORK YOGA WHEEL

RSPRO9026

Perfectly fits the human shoulder blades, allowing gentle and natural stretching of the back and realignment of the spine's natural curves. By pressing trigger points (muscle knots) and relieving back pressure, it provides a natural, non-pharmacological method to alleviate pain and increase flexibility along the neck, spine, upper back, and lower back. Cleaning: Simply wipe clean with a damp cloth (no chemicals needed), then air dry.

Dimensions: 033×W13cm
Outer ring thickness: 6mm



瑜伽柱-软木 CORK YOGA ROLLER

RSPRO9025

Incorporate balance exercises into your routine using a yoga block to enhance kinesthetic awareness and core strength, thereby improving overall coordination, stability, and posture. The yoga block also helps release tension on its own and targets trigger points, making it ideal for deep tissue massage, myofascial release, and stretching, which aids in increasing flexibility, balance, and muscle recovery. Cleaning: Simply wipe clean with a damp cloth (no chemicals needed) and allow to air dry.

Dimensions: L30×W10cm.



勒洛手抓片 REULEAUX-WEIGHT PLATE

RSPRO1006

The Reuleaux kettlebell plates are encased in a thick polyurethane coating, with three grip holes around the edges of the plate. These holes are precisely cut near the raised lip of the plate's edge, providing trainees with a comfortable and easy-to-grip hold. Each plate is compatible with any standard barbell rod diameter. Please note that this plate is not suitable for dropping during weightlifting.

Weight options: 2.5KG, 5KG, 10KG, 15KG, 20KG, 25KG

Material: Iron core + PU

Number	Specification	Size
RSPRO1006-01	2.5KG	⑦19.5×T2.5cm
RSPRO1006-02	5KG	②4.3×T3.1cm
RSPRO1006-03	10KG	③1.5×T3.7cm
RSPRO1006-04	15KG	②35.5×T4.1cm
RSPRO1006-05	20KG	③9×T4.5cm
RSPRO1006-06	25KG	①42.23×T4.8cm



勒洛直杆杠铃 REULEAUX-STRAIGHT BARBELL

RSPRO1011

勒洛曲杆杠铃 REULEAUX-CURL BARBELL

RSPRO1012

Fixed barbells are specifically designed for high-frequency environments in commercial gyms. They are made of PU (polyurethane), with polyurethane directly bonded to both ends, forming a secure connection that does not loosen over time. PU is very durable and resistant to tearing, scratching, mold, and wear; it also has excellent resistance to extreme temperatures. The handle is covered with three knurled sections along its entire length, which fit comfortably in the palm and help prevent slipping and hand abrasion. Both straight and curved bars meet your training needs. The weight markings are pure iron edges, with large yellow backgrounds and black letters (indicating weight and brand) making identification easy and ensuring clear visibility throughout the facility. It comes with a matching storage rack.

Number	Specification	Size	Number	Specification	Size
RSPRO1011-01	10kg	L108×13×T5cm	RSPRO1012-01	10kg	L108×13×T5cm
RSPRO1011-02	15kg	L108.6×15.5×T5.3cm	RSPRO1012-02	15kg	L108.6×15.5×T5.3cm
RSPRO1011-03	20kg	L110×17×T6cm	RSPRO1012-03	20kg	L110×17×T6cm
RSPRO1011-04	25kg	L112×18.5×T7cm	RSPRO1012-04	25kg	L112×18.5×T7cm
RSPRO1011-05	30kg	L114×19.5×T8cm	RSPRO1012-05	30kg	L114×19.5×T8cm
RSPRO1011-06	35kg	L116.6×20×T9.3cm	RSPRO1012-06	35kg	L116.6×20×T9.3cm
RSPRO1011-07	40kg	L118×20×T10cm	RSPRO1012-07	40kg	L118×20×T10cm



勒洛哑铃 REULEAUX-DUMBBELL

RSPRO1009

Designed for high capacity and long-term use. The robust iron head is welded to the handle, ensuring a secure connection even under heavy use. The exterior has a PU polyurethane coating, making it durable and wear-resistant with a long service life. The fully knurled steel handle provides comfortable and safe grip at any weight. The round front weight head features a bright yellow triangular shape, black clear weight markings, and brand logo, creating a stylish and premium look. Weight: 2KG-40KG. Material: Round steel + PU.

Number	Specification	Size	Number	Specification	Size
RSPRO1009-01	2kg	L20×Q13×T2.5cm	RSPRO1009-11	22kg	L27×19.5×T6cm
RSPRO1009-02	4kg	L21.5×13×T3.5cm	RSPRO1009-12	24kg	L28×19×T9cm
RSPRO1009-03	6kg	L23.5×12.5×T4cm	RSPRO1009-13	26kg	L29×19.5×T9cm
RSPRO1009-04	8kg	L23.5×15.5×T4.5cm	RSPRO1009-14	28kg	L30.5×19×T7.5cm
RSPRO1009-05	10kg	L24×15.5×T4.5cm	RSPRO1009-15	30kg	L31×19.5×T8cm
RSPRO1009-06	12kg	L26.6×15×T5.6cm	RSPRO1009-16	32kg	L35.5×17.5×T8.5cm
RSPRO1009-07	14kg	L27×15.5×T6cm	RSPRO1009-17	34kg	L33.5×20×T9cm
RSPRO1009-08	16kg	L28×17.5×T6.5cm	BPB01009-18	36kg	L34.5×20×T9.5cm
RSPRO1009-09	18kg	L27.5×17.5×T6cm	RSPRO1009-19	38kg	L36×20×T10cm
RSPRO1009-10	20kg	L30×17.5×T7.4cm	RSPRO1009-20	40kg	L37×20×T10.5cm



臀推专用杆 HIP THRUSTER BAR

RSPRO1040

Designed specifically for hip thrust movements, it is shorter and thicker than traditional standard push bars. It can more effectively distribute load and make upward pushes more comfortable. The length of the bar also provides greater stability during hip movements, maximizing stimulation of the hip muscles. The distance between the clamps can be adjusted according to personal needs; compatible with standard Olympic plates.

Weight capacity: 450kg / comes with protective pads.

Dimensions: bar L150×W5×H0.3cm, pads L46×W12×H3.5cm.

Weight: 6.5 kg.



农夫行走杆 FARMERS WALK BAR

RSPRO1052

Lifting and walking in the correct posture, which causes prolonged muscle tension, simulates the process of farmers carrying heavy loads to warehouses, helping to train all types of athletes for greater strength endurance. Although variations of the farmer's walk can be performed using dumbbells or kettlebells, this bar matches standard weight plates, meaning any athlete can quickly adjust their weight. Knurled handles, black powder-coated finish.

Dimensions: Bar L120×T0.2×D4.8cm Handle L66×H15×Q3.2cm

Weight: 5kg per bar.



安全深蹲杆 SAFETY SQUAT BAR

This barbell is designed for individuals with injuries or limited joint mobility. The weight distribution at the ends of the barbell differs from that of a standard barbell, forcing the user to maintain an upright position during squats and requiring more stability from the upper back and core. The handle is more accommodating for those with shoulder, elbow, or wrist limitations, or for those with larger frames. The distance between the bends of the bar (125 cm) fits even on wider racks. The shoulder pads are covered with high-density foam and textured leather, making them durable and easy to clean. The bar features black ceramic grips and hard-chrome sleeves compatible with standard Olympic plates and collars.

Dimensions: total length 220 cm, grip diameter 2.5 cm, spacing L125 × 3 cm, load capacity 350 kg.

Weight: 20 kg.



开放式六边框 OLYMPIC OPEN TRAP BAR

RSPRO1021

The open hexagonal design of the geometric shape allows the body to bear better loads; the open design enables a lateral grip on the handle, suitable for movements such as lifting and walking, making weightlifting easier (especially with two different handle heights). Using an open hexagon not only avoids friction with the calf skin but also helps maintain an upright torso during use, reducing shear force on the spine and allowing training benefits to be more effectively transferred to vertical jump training.

Dimensions: 210×14.5×64.5 cm Material: Tube T3mm/Plate T8MM

Static load test: 800 kg



单腿深蹲架 SINGLE LEG SQUAT RACK

RSPRO1049

Most sports techniques are performed on one leg (except rowing), but unfortunately, many current strength training programs still focus only on traditional two-legged exercises such as squats and deadlifts. In reality, most people do not have the need or experience for heavy weight training, and unilateral strength is crucial for improving speed, balance, and preventing injuries. The single-leg squat rack offers eight adjustable heights; it also features a single-hand push/pull handle and roller mobility, which are the main reasons why professionals prefer this squat rack.

Patent number: 202330680210X

Dimensions: L45×W45×H85cm

Roller dimensions: L45×Ø12.7cm

Weight: 15kg



力量T把 POWER T HANDLE

RSPRO1038

This is a multifunctional load plate device, particularly suitable for squat racks and pendulum movements. The power T handle can also be used for sumo and regular training. The load sleeve made of pure steel has a matte spray finish and is compatible with Olympic plates; it can also be used with resistance bands. The ergonomic handle design ensures grip (both straight and overhand holds). It features adjustable length and weight magnetic pins for quick and easy weight adjustments.

Note: It is recommended to use 10 kg plates, with a load capacity of 70-150 kg.



可调节训练凳 ADJUSTABLE SIT UP BENCH

RSPRO1023

A multifunctional flat inclined adjustable training bench. It features seven different backrest adjustments (from 85 degrees to 20 degrees) and five seat positioning methods, totaling 21 possible configurations. The chrome-plated ladder adjustment system allows for quick selection between exercises. The front has an attachment for fixed feet; the rear includes wheels for easy mobility. The overall weight capacity is tested at 450 kg. Anti-slip pads made of textured, high-grip vinyl provide additional shoulder support.

Dimensions: L160.5×W66×H43.8 cm,

Weight: 42 kg.



重型训练平凳 HEAVY DUTY FLAT BENCH

RSPRO1022

A flat, competition-style bench that meets the height standards of weightlifting federations. With a stable tripod leg design for comfortable leg positioning. The high-density foam pad is made from heavy-duty non-slip vinyl, providing stability and supporting up to 450 kg as tested. Integrated steel handles and industrial wheels make it easy to move. Grooved rubber feet help secure the bench in place while protecting the floor.

Dimensions: L123×W50×H44cm

Weight: 30kg



重训罗马椅 GLUTE HAM DEVELOPER

RSPRO1024

The Roman chair for heavy training strengthens the posterior chain muscles (glutes, hamstrings, and lower back). This versatile equipment has 13 different adjustment points, suitable for most people of varying heights. The bearing system on the footplate allows for quick and easy height adjustments, and the footplate aids users in getting on and off the equipment. This Roman chair is made entirely of steel. The foot pads feature wear-resistant vinyl covers and are equipped with steel end caps. Despite weighing 80 kg, it comes with wheels for easy mobility. Resistance bands can be attached using the provided pegs to add variety to workouts, allowing for targeted abdominal exercises by flipping the body in addition to strengthening the posterior chain.
Weight: 60 KG
Dimensions: 78 × 93 cm when folded, 168 × 10.5 × 114 cm when unfolded.



反向抬腿器 REVERSE HYPER EXTENSION MACHINE

RSPRO1025

The reverse leg lifter is an excellent choice for increasing strength, power, speed, and reaction time in the posterior chain. Reverse stretching thoroughly trains the erector spinae, glutes, and back of the legs. It is not only an efficient arm blaster but also ideal for rehabilitation. Bolt assembly design; oversized platform pad for better comfort; adjustable front handles to accommodate trainees of different heights.
Weight: 132KG
Dimensions: L131×W108×H118.5cm



竞赛组合架 COMPETITION COMBO RACK

RSPRO1026

The squat and press combination rack has been excellently redesigned, adding durability and safety tubing, showcasing a stylish design silhouette with unique details, and improving lifting, loading, and easy disassembly. The robust yet innovative design integrates support for inclined support points, used for adjusting arm angles, making it simpler and easier to operate while providing additional safety protection for the rack. These geometric designs are favored by weightlifters, making it a performance-enhancing rack.

Weight: 180KG

Dimensions: L205×W163×H139-196cm



可调节跨栏 ADJUSTABLE TRAINING AGILITY HURDLE

RSPRO2010

Improve coordination, lateral movement, and foot speed skills. The hurdles are made of sturdy yet lightweight PVC, shaped to the correct curvature through heating processes. They can switch heights and fold at the rotating bend. For safety, the curved design ensures they always tilt forward when bumped, making them visible even during night training due to their yellow color. Use them with agility poles and ladders for comprehensive speed and agility exercises. Dimensions: H22/30×Ø2cm.



弓箭障碍栏 SPEED HURDLE

RSPRO2007

The hurdle barriers are perfect for hurdle training and testing exercises. Made of sturdy PVC, they can be adjusted to three different heights using buckle fasteners, and feature reinforced bases for stability. The telescopic legs make storage convenient. Dimensions: H15/23/30cm.



V型敏捷梯 V-SHAPED AGILITY HURDLES

RSPRO2012

The V-shaped agility ladder is a wonderful and popular training aid that can improve foot speed, agility, coordination, and balance. The V-shaped flat ladder creates grids with 45 cm interval markings. The ends of the ladder have hooks and ring attachments, allowing multiple ladders to be connected.

Dimensions: L570×W45cm



圆形敏捷圈 ROUND AGILITY CIRCLE

RSPRO2006

Restricts and positions functions, standardizes technical movements, simulates real combat scenarios in physical training, optimizes the ability for accurate technical actions during rapid movement, innovates various training modes based on teaching needs, and provides new challenges for trainees. Snap-fit connections make assembly and carrying convenient. Suitable for: ball sports, fitness enthusiasts, specialized physical training, children's games, etc.

Size: ① 40/50/60/70 cm

Specifications: 4 pieces / 0.5 kg



八边形敏捷圈 OCTAGONAL AGILITY CIRCLE

RSPRO2005

Restricts and positions functions, standardizes technical movements, simulates real combat scenarios in physical training, optimizes the ability for accurate technical movements during rapid motion, innovates various training modes based on teaching needs, providing trainees with new challenges. Snap-fit connections make assembly and carrying convenient. Suitable for ball sports, fitness enthusiasts, specialized physical training, children's games, etc.

Size: 54cm.

Specifications: 6 compartments/1kg.



可折叠六边圈 FOLDABLE HEXAGONAL AGILITY RING

RSPRO2026

Restricts and positions functions, standardizes technical movements, simulates real combat scenarios in physical training, optimizes the ability for accurate technical actions during rapid movement, innovates various training modes based on teaching needs, providing trainees with new challenges. One circle has four clip positions, making assembly and carrying convenient. Suitable for ball sports, fitness enthusiasts, specialized physical training, children's games, etc. Patent number: 201920839119.6.

Dimensions: 52 cm.

Specifications: 6 sections/1.1 kg.



三角形敏捷圈 TRIANGULAR AGILITY CIRCLE

RSPRO2001

Restricts and positions functions, standardizes technical movements, simulates real combat scenarios in physical training, optimizes the ability for accurate technical movements during rapid motion, innovates various training modes based on teaching needs, providing trainees with new challenges. Snap-fit connections make assembly and carrying convenient. Suitable for ball sports, fitness enthusiasts, specialized physical training, children's games, etc.

Dimensions: L48 × L48 cm.

Specifications: 6 compartments / 0.7 kg.



可调节弹力管 ADJUSTABLE ELASTIC EXPANDER TUBE

RSPRO2020

Adjustable resistance tubes add variety to resistance training. This kit includes movable anchor straps that allow for training on multiple planes using dynamic exercises such as rotations, punches, and chops to build balanced muscles and increase flexibility. Ergonomically designed handles work together up to a total resistance of 180 pounds. Resistance tubes can be easily changed within seconds to adjust resistance levels according to fitness level and muscle strength, endurance, and performance improvement.

Note: Inspect for wear before each use.

Dimensions: L120×0.9×T0.06cm.

三孔绕杆 AGILITY POLES

RSPRO2013

The agile pole with a heavy-duty rubber base is perfect for use on hard court surfaces or outdoor lawns. Adding rubber caps to both ends of the pole provides extra safety, and the comfortable fit of the base allows the holes to be easily picked up and moved.

Dimensions: L100×H150cm



针织阻力带 TEXTILE RESISTANCE BAND

RSPRO0038

This is an alternative to traditional rubber bands, with the advantage of slow aging and greater comfort when in contact with the body. Despite its soft feel, the extended resistance band has exceptional elasticity and wear resistance; it comes with cuffs that can quickly secure it around the waist and hips for technical training such as acceleration, deceleration, and sprinting. Material: Polyester + Latex thread
Dimensions: W190×H6×T0.5cm



战斧球袋 TOMAHAWK BALL SACL

RSPRO2042

A bag designed with straps to secure a ball, adding new training actions such as spinning, swinging, bundling, and chopping for medicine balls. After securing the ball, perform kettlebell swings, Russian twists, reverse swings, and big hammer exercises to develop strength and explosiveness on multiple planes. Adjust the difficulty by changing the weight of the ball. The bag is suitable for balls with a diameter less than 25 cm and works best with resistance balls, sand balls, or medicine balls specifically designed for impact training. The grip ropes have three adjustable lengths with a knot at the end to prevent slipping and potential danger. Note: Sold individually, does not include demonstration ball.



核心皮革甩球 STRONGMAN BAG

RSPRO2027

Supplement all the advantages of croissant training by adding extra features. Beginners should start with the lightest weight, and each increase in weight presents new challenges and goals while focusing on developing speed, endurance, and strength. The specially designed, sturdy, and easy-to-grip handle allows for comfortable and greater dynamic rotation exercises during fast and dynamic training modes. Detachable handles allow for various uses of the ball, including as a traditional medicine ball. Various weight options are provided for any level of training, from athletes to fitness enthusiasts to teenagers! Note: Carefully check for wear and tear before each training session.



六角反应球 SUPER REACTION BALL

RSPRO2037

The sphere has six protruding rounded corners, and the six protruding surfaces create randomness during the bounce-back process, making it difficult for the user to catch it. This tests the observer's eye and brain reaction capabilities. It is used to train reaction speed, agility, footwork, lateral movement, and overall responsiveness.

Dimensions: 7cm

Weight: 130g



女士负重背心 WOMEN'S WEIGHT VEST

RSPRO2028

Weight vests can provide additional weight to the body, making them an ideal way to increase load. They securely fasten around the torso, ensuring that the weight path of the body feels more 'authentic' during training without interfering with changes in movement patterns. They are more convenient and comfortable than other loading methods, such as running, push-ups, agility training, and jumping. Both models have been tested through training and have been redesigned to accommodate both male and female physiques, making them favorites among seasoned trainers. Note: To maintain the longevity of the vest, avoid rubbing it against rough surfaces.

Size: L44×W30×H35cm

Weight: 10kg



反应捕捉棒 REACTIVE CATCH

RSPRO2044

Throw it into the air, call out a color, and have the opponent catch it, or perform an action that you haven't done before each time you catch it. By involving both the brain and body during training, this method develops motor intelligence and enhances reaction skills, thereby improving athletic performance. It can be used for almost all sports training, commonly for pre-game warm-ups and similar scenarios in individual or team training sessions. It is also a tool for warming up before sports lessons, interactive activities before youth classes, and family entertainment games. The triangular design has real round ends, making it easy to catch and throw. Dimensions: L20×W20×D4cm. Specifications: Yellow, red, gray / 70g.



男士负重背心 MEN'S WEIGHT VEST

RSPRO2030

Weight vests can provide additional weight to the body, making them an ideal way to increase load. They securely fasten to the torso, ensuring that the body's weight path feels more realistic and does not interfere with changes in movement patterns. They are more convenient and comfortable than other loading methods, such as running, push-ups, agility training, and jumping. Both vest models have been tested during training and have been redesigned to accommodate both male and female physiology, making them a favorite among seasoned trainers. Note: To maintain the longevity of the vest, avoid rubbing it on rough surfaces.

Size: L45×W32×H35cm

Weight: 20kg



四轴滑车 GLUTE HAM ROLLER

RSPRO2036

A simple and innovative design allows for leg curls and abdominal exercises without putting pressure on the knees as Nordic curls might. Even those with slight pain can perform the movements smoothly, making it very kind to the joints and more functional and practical compared to other posterior leg training equipment. Its unique and stable structure serves as a practical tool for both front chain and back chain.



三合一支架 3-IN-1 PARALLETES

RSPRO2049

The three-in-one bar is used for performing handstand push-ups, L-shape, V-shape, and many other gymnastic exercises. The 'three-in-one' refers to three different handle diameters, allowing trainees to adjust their workouts based on variety and intensity. Each unit weighs 5 kg net, and its wide support surface makes it very stable. The handle diameters are: 32 mm, 38 mm, and 50 mm.

Dimensions: L37 x W33 x H32/38/50 cm.

Weight: 5 kg per unit.



H型支撑架 H-TYPE PARALLEL BARS

RSPRO2029

The H-shaped support frame is designed for stability and efficiency, making it perfect for bodyweight exercises and training arm and core strength. Whether you choose to exercise indoors or outdoors, the support frame is ideal for performing push-ups, handstands, front levers, stretching exercises, and more bodyweight workouts. It can support up to 150 kg of weight.

Dimensions: L60×W40×H40cm

Weight: 5kg



臀肌箱 GLUTEUS BOX

RSPRO2033

The glute bench is made of high-density foam, providing the possibility to perform a series of exercises centered on the buttocks in a comfortable and effective manner. It can be used as a standard glute bridge for arm exercise comfort, enhancing training efficiency and comfort during workouts. This led us to develop this glute bench capable of heavy-duty training.

Test: No deformation at 300kg

Dimensions: L70×W70×H43/33cm

Specifications: Yellow/26kg



3合1专业跳箱 3-IN-1 FOAM PLYO BOX

RSPRO2039

The soft-padded 3-in-1 jump box eliminates the risk of scratches and collisions to the shins, making it an essential piece of equipment for functional training to increase strength and muscle tension. This versatile and high-quality box is robust and durable, featuring wooden material inside, EVA foam filling in the middle layer, and anti-slip leather wrapping on the outside. It has a moderate weight that won't move around. By rotating the box, you can achieve three different height levels: advanced model at 40/50/60 cm (18 kg), professional model at 50/60/75 cm (21 kg). It is commonly used for exercises such as high plank push-ups, stepping up, jumping, and landing.



渐进式跳箱 FOAM PLYOBOX SET

RSPRO2034

The progressive jump box is both soft and stable, allowing for various exercises at different heights. The heavy-duty nylon buckles on all sides securely stack together. The wide base leaves ample landing space when jumping, and the dimensions of each layer are printed on both sides. The box features cross-stitch handles and is lined with dense foam that protects your calves and joints by absorbing impact. This foam also adds weight to the box, making it highly resistant to tipping. Both the top and bottom surfaces are covered with durable, non-slip material, so you can flip, drag, or push the box without worrying about damage.

Number	Color	Weight	Top-Bottom	Side-Corner	Height
RSPRO2034-01		8kg	65×100cm	6cm	15cm
RSPRO2034-02		16kg	65×100cm	6cm	30cm
RSPRO2034-03		24kg	65×100cm	6cm	45cm
RSPRO2034-03		32kg	65×100cm	6cm	60cm



12边手抓片 12 SIDE GRIP PLATES RSPRO8006

Minimum order quantity: 5 pieces/unlimited specifications

Manufacturing process: laser engraving plus filling adhesive

Product features: CPU polyurethane surface, core made of round steel, electroplated round steel handle

Process: one-time casting, sandblasted surface

Advantages: environmentally friendly, odorless, good elasticity, wear-resistant, and impact-resistant

Specifications: 10kg-60kg

Interval: 5kg

Tolerance: $\pm(1\%-3\%)$

RSPRO8006-01	1.25kg	②171×T21mm
RSPRO8006-02	2.5kg	0238×T24mm
RSPRO8006-03	5kg	0280×T29mm
RSPRO8006-04	10kg	0345×T32mm
RSPRO8006-05	15kg	0364×T43mm
RSPRO8006-06	20kg	0384×T47mm
RSPRO8006-07	25kg	②404×T50mm



轮毂手抓片 HUB GRIP PLATES RSPRO8007

Minimum order quantity: 6 pieces per specification

Manufacturing process: laser engraving plus filling

Material: CPU polyurethane matte surface, steel core, stainless steel hole sleeve; one-piece casting

Advantages: environmentally friendly, odorless, good elasticity, wear-resistant, and impact-resistant

Hole diameter: 52mm

Tolerance: $\pm(1\%-3\%)$

RSPRO8007-01	2.5kg-黑	0240×T20mm
RSPRO8007-02	5kg-黑	①300×T28mm
RSPRO8007-03	10kg-绿	⑦360×T34mm
RSPRO8007-04	15kg-黄	0390×T38mm
RSPRO8007-05	20kg-蓝	0420×T41mm
RSPRO8007-06	25kg-红	0450×T43mm



训练片-黑 TRAINING PLATES -BLACK RSPRO8008

Minimum order quantity: 6 pieces per specification

Manufacturing process: screen printing

Product features: stainless steel hole sleeve, overall vulcanization

Advantages: environmentally friendly, odorless, high elasticity, durable, withstands 15,000 drop tests

Hole diameter: 52mm

Tolerance: $\pm(1\% - 3\%)$

RSPRO8008-01	05kg-黑	045×T2.3cm
RSPRO8008-02	10kg-黑	①45×T4.1cm
RSPRO8008-03	15kg-黑	245×T5.8cm
RSPRO8008-04	20kg-黑	045×T7.5cm
RSPRO8008-05	25kg-黑	245×T8.9cm



比赛片-彩 COMPETITION PLATES -COLOURED RSPRO8009

Minimum order quantity: 6 pieces per specification

Manufacturing process: screen printing

Product features: hard chrome flange steel plate, fully vulcanized

Advantages: environmentally friendly, odorless, high elasticity, durable, withstands 15,000 drop tests

Hole diameter: 52mm

Tolerance: $\pm(1\%-2\%)$

RSPRO8009-01	05kg-黑	245×T2.3cm
RSPRO8009-02	10kg-绿	045×T2.8cm
RSPRO8009-03	15kg-黄	045×T4.8cm
RSPRO8009-04	20kg-蓝	045×T5cm
RSPRO8009-05	25kg-红	045×T5.5cm



1 竞技壶铃 COMPETITIVE KETTLEBELL

RSPRO8001

Minimum order quantity: 5 units/unrestricted specifications

Manufacturing process: one-piece adhesive

Material: surface CPU, steel sand filling, handle hard chrome

Features: different weights, same size, matte surface, molded as a whole

Advantages: environmentally friendly, odorless, good elasticity, wear-resistant and impact-resistant

Specifications: 6kg-28kg

Tolerance: ±(1%-3%)

Number	Specification	Total Length	Number	Specification	Total Length
RSPRO8001-01	6kg-黑蓝	0215×H300mm	RSPRO8001-05	16kg-黑黄	②215×H300mm
RSPRO8001-02	8kg-黑粉	0215×H300mm	RSPRO8001-06	20kg-黑紫	0215×H300mm
RSPRO8001-03	10kg-黑粉	0215×H300mm	RSPRO8001-07	24kg-黑绿	0215×H300mm
RSPRO8001-04	12kg-黑蓝	0215×H300mm	RSPRO8001-08	28kg-黑橙	0225×H320mm



1 训练壶铃 TRAINING KETTLEBELL

RSPRO8002

Minimum order quantity: 5 pieces, no specification limit

Manufacturing process: mold inserts

Material: surface CPU, inner core cast iron, handle hard chrome

Features: different weights, different sizes, matte surface, cast as a whole

Advantages: environmentally friendly, odorless, good elasticity, wear-resistant and impact-resistant

Specifications: 4kg-40kg

Tolerance: ±(1%-3%)

Number	Specification	Total Length	Number	Specification	Total Length
RSPRO8002-01	4kg	H180×W150×Q105mm	RSPRO8002-08	18kg	H280×W195×Ø180mm
RSPRO8002-02	6kg	H195×W150×Ø120mm	RSPRO8002-09	20kg	H290×W195×Ø185mm
RSPRO8002-03	8kg	H225×W180×135mm	RSPRO8002-10	24kg	H305×W195×Ø190mm
RSPRO8002-04	10kg	H235×W188×Ø140mm	RSPRO8002-11	28kg	H310×W195×Ø210mm
RSPRO8002-05	12kg	H245×W188×160mm	RSPRO8002-12	32kg	H320×W195×Ø220mm
RSPRO8002-06	14kg	H275×W195×Ø160mm	RSPRO8002-13	36kg	H330×W195×Ø225mm
RSPRO8002-07	16kg	H280×W195×Ø170mm	RSPRO8002-14	40kg	H340×W195×Ø230mm



1 12边哑铃 12 SIDE DUMBBELL

RSPRO8003

Number	Specification	Total Length	Number	Specification	Total Length
RSPRO8003-01	2.5kg	0215×H300mm	RSPRO8003-13	32.5kg	0215×H300mm
RSPRO8003-02	5kg	①215×H300mm	RSPRO8003-14	35kg	⑦215×H300mm
RSPRO8003-03	7.5kg	0215×H300mm	RSPRO8003-15	37.5kg	0215×H300mm
RSPRO8003-04	10kg	0215×H300mm	RSPRO8003-16	40kg	⑦225×H320mm
RSPRO8003-05	12.5kg	①215×H300mm	RSPRO8003-17	42.5kg	①215×H300mm
RSPRO8003-06	15kg	①215×H300mm	RSPRO8003-18	45kg	0215×H300mm
RSPRO8003-07	17.5kg	0215×H300mm	RSPRO8003-19	47.5kg	0215×H300mm
RSPRO8003-08	20kg	①215×H300mm	RSPRO8003-20	50kg	⑧225×H320mm
RSPRO8003-09	22.5kg	0215×H300mm	RSPRO8003-21	52.5kg	0215×H300mm
RSPRO8003-10	25kg	0215×H300mm	RSPRO8003-22	55kg	②215×H300mm
RSPRO8003-11	27.5kg	①215×H300mm	RSPRO8003-23	57.5kg	0215×H300mm
RSPRO8003-12	30kg	0215×H300mm	RSPRO8003-24	60kg	0225×H320mm

1 12边杠铃-直杆 12 SIDE BARBELL-STRAIGHT

RSPRO8004



Number	Specification	Total Length	Number	Specification	Total Length
RSPRO8004-01	10kg	L988/930×Ø32mm	RSPRO8005-10	10kg	L988/930×Ø32mm
RSPRO8004-02	15kg	L1022/930×Ø32mm	RSPRO8005-11	15kg	L1022/930×Ø32mm
RSPRO8004-03	20kg	L1040/930×Ø32mm	RSPRO8005-12	20kg	L1040/930×Ø32mm
RSPRO8004-04	25kg	L1068/930×Ø32mm	RSPRO8005-13	25kg	L1068/930×Ø32mm
RSPRO8004-05	30kg	L1070/930×Ø32mm	RSPRO8005-14	30kg	L1070/930×Ø32mm
RSPRO8004-06	35kg	L1100/930×Ø32mm	RSPRO8005-15	35kg	L1100/930×Ø32mm
RSPRO8004-07	40kg	L1120/930×Ø32mm	RSPRO8005-16	40kg	L1120/930×Ø32mm
RSPRO8004-08	45kg	L1144/930×Ø32mm	RSPRO8005-17	45kg	L1144/930×Ø32mm
RSPRO8004-09	50kg	L1195/930×Ø32mm	RSPRO8005-18	50kg	L1195/930×Ø32mm

1 12边杠铃-曲杆 12 SIDE BARBELL-CURL

RSPRO8005

Minimum order quantity: 5 pieces/unlimited specifications

Manufacturing process: laser engraving plus filling adhesive

Product features: CPU polyurethane surface, core made of round steel, electroplated round steel handle

Process: one-time casting, sandblasted surface

Advantages: environmentally friendly, odorless, good elasticity, wear-resistant, and impact-resistant

Specifications: 10kg-60kg

Interval: 5kg

Tolerance: ±(1%-3%)



多功能形体棍 MULTIFUNCTIONAL WOODEN BODY STICK

RSPRO7002

MULTIFUNCTIONAL WOODEN BODY STICK

RSPRO7002

The body stick is one of the most common tools used in shape training/dance/fitness courses. Beginners can use it for movement pattern practice, advanced athletes use it for pre-workout warm-ups, and professional coaches use it for teaching and guidance. Its main functions are posture correction and movement pattern practice, providing direction and adjustment for correct training movements.

Dimensions: L140×D2.8cm



跳远测试垫 LONG JUMP MAT

RSPRO7006

The jumping mat measures the horizontal jump distance, making it an ideal choice for the standing long jump test. It features a non-slip base with cushioned PVC material, marked with yellow numbers and lines at 1-meter intervals, then every 5 centimeters until the end.



指夹血氧仪 FINGER CLIP PULSE OXIMETER

RSPRO7004

Maintaining life involves ensuring adequate oxygen supply within the body. Red blood cells in the blood are responsible for transporting oxygen. A pulse oximeter is a device that can measure the oxygen content in the blood. Real-time blood oxygen monitoring of athletes after high-intensity training helps understand their circulatory condition post-exercise, allowing for adjustments in exercise volume planning. Dimensions: L50cm.



皮围测试套装 BODY FAT CALIPER

RSPRO7005

An important tool for achieving personal fitness goals, tracking fitness goals helps monitor progress and maintain motivation. By detecting circumference and fat thickness, it determines the starting point of a fitness plan, the room for improvement, and whether adjustments need to be made to the training plan.

Dimensions: L16.5×W10cm

L8.5×W6.3×T2cm



动作评估套件 FUNCTIONAL MOVEMENT SCREEN

RSPRO7007

It is a basic assessment of motor abilities through simple quantification, testing the stability and flexibility of the subject during seven actions; it also evaluates the size of asymmetries between sides, as well as any pain or functional impairments present; thus, it estimates the risk of movement injuries for the test subject while providing directional guidance for their rehabilitation treatment or physical exercise training.

Dimensions: L152×W13.5×H4.5cm

03.2×L120cm×1 piece

②3.2×L60cm×2 pieces



关节活动度测量尺 JOINT RANGE OF MOTION MEASURING INSTRUMENT

RSPRO7008

The goniometer is an ideal instrument for mapping spinal curvature and measuring lateral movement. Place the goniometer near the joint to be measured. As the joint is manipulated, the range of motion will be displayed on the scale in degrees. Rotate the scale until it reads zero, then directly read the data from the scale. For neck and back measurements, two goniometers are sometimes required simultaneously. Suitable for measuring joint flexion, extension, abduction, adduction, dorsiflexion, and plantarflexion. Dimensions: L8×W10×T1cm.

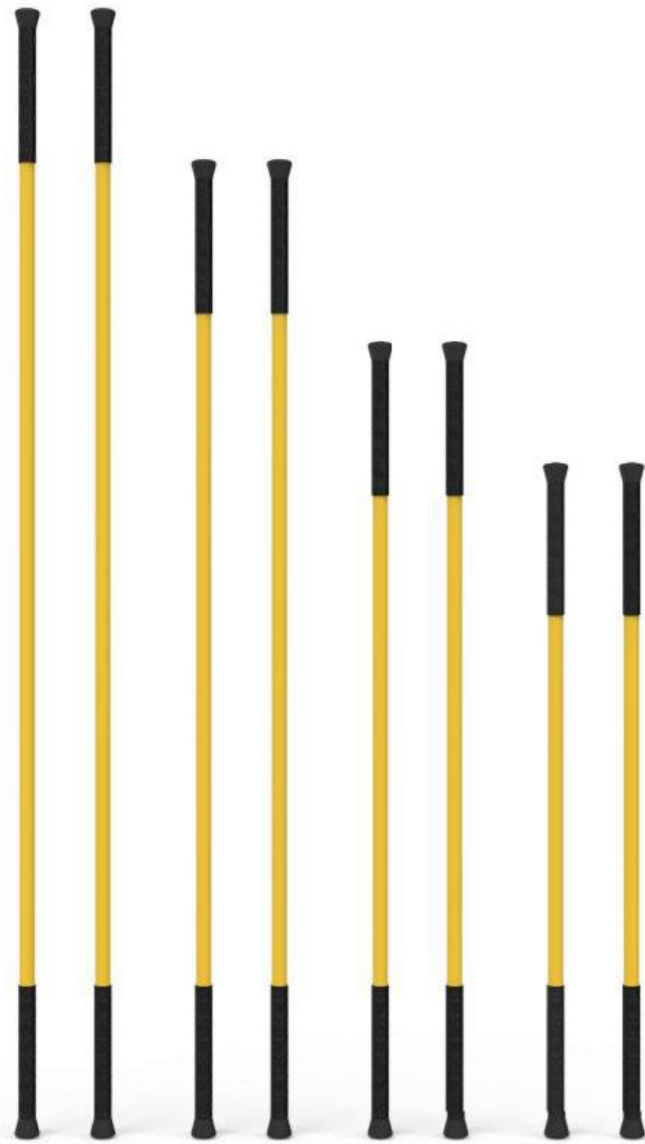

筋膜伸展训练棒 FASCIA EXTENSION TRAINING STICK

RSPRO7009

The training sticks are meticulously designed to provide sufficient elastic strength within their structure, functioning as training tools that create leverage principles. They combine joint flexibility, strength training, and active stretching to improve coordination and develop body awareness; systematically enhancing flexibility and stability, they deeply stretch fascia that is difficult to reach on a daily basis, laying a solid foundation for improving athletic performance. Select one long and one short training stick based on height to practice specific movements, making it easy to effectively train the entire body, which helps to improve sports performance, reduce injury risk, and speed up recovery.

Note: Single-stick training is advanced; double-stick training is intermediate.

Number	Specification	Weight	Usage	Selection
RSPRO7009-01	L125×033.5cm	0.9kg	Activate and fluidity actions	Height/Reach under 1.78 meters
RSPRO7009-02	L155×033.5cm	1kg		Height/Reach under 1.78 meters
RSPRO7009-03	L185×033.5cm	1.6kg	Other functional actions	Height/Reach under 1.78 meters
RSPRO7009-04	L215×033.5cm	1.7kg		Height/Reach under 1.78 meters

Training Timing

- Flexibility training for joints can be done every day.
- Integrate controllable training content into warm-up and relaxation exercises during daily activities.
- Only two high-intensity movements per session, with each part of the body trained for 1-2 minutes.

Training Principles

- Utilize stretching bars as levers; maintain stability while breathing naturally for better stretching effects.
- Focus on common training methods for postoperative rehabilitation and sports injuries (static, self-initiated, and resisted).
- Adjust the position of the bar and use proprioception to correct movements.

Training characteristics:

- Maximizes stimulation of the body at specific angles to achieve ideal training results.
- Generally not too strenuous, suitable for use during the final preparation phase and warm-up recovery period.
- Improves proprioception and technical skills by visually observing movement quality and making corrections.



纵跳摸高测试-壁挂 VERTICAL JUMP TESTER-WALL-MOUNTED

RSPRO7010

The telescopic steel frame is designed for measuring and improving vertical jump height. The adjustable height ranges from 120cm to 360cm. The rotating recording blades increment by 2cm intervals (a total of 30 yellow and black blades) to accurately measure and record the vertical jump heights of athletes at various levels.

Wall-mounted models are easy to fix on the walls of training grounds, making them convenient for repeated use. Floor-standing models are easy to move and suitable for different indoor and outdoor scenarios. Both models come with a reset toggle switch.

Jumping methods:

- In place: Stand directly below the equipment, swing your arms vigorously to jump up, and touch the blades with your head or hands. The height achieved is the vertical height.
- Running start: Stand a certain distance from the apparatus, sprint forward, and jump. Touch the blades with your head or hands. The height achieved is the absolute height.

Measurement Steps

1. Stand still and raise one hand as high as possible, record the height of your fingertips.
 2. Jump up with force and record the height your fingertips reach.
 3. The difference between the jumping fingertip height and the standing fingertip height is your score.
- Note: The nail length of the person being tested must not exceed 0.3 cm beyond the fingertip.

纵跳摸高测试-落地 VERTICAL JUMP TESTER-TO GROUND

RSPRO7011

Suitable venues: professional teams gyms, fitness centers, sports colleges, and other places for jump performance assessments.



model:	AMSB-03-BA
Color:	Black/Industrial Coating
texture of material:	Mixed material
Net weight:	57.6kg
Power Supply:	battery
Screen:	Bluetooth/ANT+function
Assembly size:	125×52×120cm
Seat adjustment:	Front and back 4cm/up and down 30cm/angle 30 °
Control panel range:	Height 30cm/angle 270 °
Handle position:	Adjustable 19cm
Resistance range:	Air level 10, magnetic resistance level 8
Maximum load-bearing capacity:	159kg
Shipping weight:	66kg
Shipping size:	137×42×110cm

RSPR01001

风阻单 IR PLUS CYCLE

Utilizing air resistance to make cycling smoother, the damper on the left side of the flywheel allows riders to adjust the airflow during cycling to increase or decrease intensity. Unlike most stationary bicycle trainers, it is equipped with a clutch that can simulate a real bicycle. When pedaling stops, even if the flywheel is rotating, the pedals will not move. Riders can easily track the resistance level set by the resistance gauge using a large console display, allowing for quick data feedback while training. Simultaneously track the training progress.



Easy to adjust
The handlebar height can be adjusted 30 levels, across the range of 19 cm, or forward and backward along the range of 7.56 inches. The console is tilted 270 degrees for convenient and quick viewing. The height of the seat pillar can be adjusted by 30 levels within a range of 30 centimeters. The seat is adjusted forward/backward by 10 cm and inclined by 30 degrees. The steel mesh wrapping facing the rider blocks the direction towards the rider's face. Any uncomfortable air/wind in the body and body, include Metal pedals with foot cups.



Comfortable riding
The 58 kilogram base can withstand a weight of 159 kilograms. The mixed material includes two front wheels, making storage and transportation easier. Use a double reinforced groove belt with a self tension system. The belt driven cycle provides a smooth and quiet experience. The frame tilts upwards, making it easy and convenient to adjust the damper settings.



Performance control center
The control panel is a display that directly indicates the level of the damper. The monitor always displays the resistance level of the air damper. Time, distance, calories RPM, Watt Speed, pulse, and lag when switching modes. Li/hour. Easy to read console designed to simplify. And the ability to keep track of your progress at any time.



Program compatibility
The Bluetooth connection used by the Peloton application is linked to the Smart Connect console. If you plan to connect your bike to the Peloton application, you will need to purchase a separate 'Peloton compatible sensor'. If you need to connect to the Peloton application for tracking, we recommend using the Arkon tablet stand.



model:	AB-1000-E
Color:	Black/Industrial Coating
texture of material:	Mixed material
Net weight:	44.6kg
Power Supply:	battery
Screen:	convention
Space requirements	129×59×127cm
Occupation size:	122×65cm
Maximum load-bearing capacity:	150kg
Fan size:	Windblade 6 1cm, hood 6 9cm
Seat adjustment:	Up and down/front and back/adjustment stop
General control console:	Time, calories burned, heart rate, distance
Preset goals:	Time/Distance/Calories/Heart Rate
Shipping weight:	51kg
Shipping size:	127×59×129cm

RSPRO1002

风阻自行车 AIR BIKE

The best choice for beginners and professionals, regardless of your exercise, physique, or achieving greater goals. Modern design, equipped with reinforced pedals and cranks, a 27 inch resistance fan, an industrial powder coated frame, and an easy to read console, with pre built custom interval programs, this drag bike provides you with an exhilarating fitness experience. Self control determines speed, comfort, and resistance. It is more robust than its counterparts in the market and has more durable moving parts.

AB-1000-E is a sturdy wind resistance bike that can withstand the most challenging exercises.



Effective exercise
The resistance is controlled by the trainer and equipped with a 69 centimeter resistance fan. Accelerate pushing, pulling, and stepping to activate arms, chest, back, legs, and core, the faster the speed. The greater the intensity. By slowing down thrust, tension, and pedaling Plate travel/speed to reduce strength (cold body).



Low maintenance design
Whether you are training indoors or outdoors, the AB-1000-E will take convenience to a whole new level. The level. Its compact, user-friendly, and cordless design allows you to exercise anytime, anywhere. Equipped with movable wheels and four adjustable stabilizing feet, it is easy to move and store.



Performance control center
The console provides exercise plans for both endurance and high fitness HIT training, tailored to exercise preferences. Customization and real-time tracking of progress (time, burning) Calories, heart rate, distance). Pre selectable options. Calories, distance, time or heart rate, experience full Vitality exercise.



sturdy and durable
Sealed with 20 key bearings and durable moving parts, utilizing the highest technology of fitness bicycles, using heavy-duty options. Steel frame and all metal pedals, reinforced pedals and cranks for additional strength.



FOCUS系列垫 FOCUS SERIES MAT

RSPRO4036

FOCUS pads are made of legendary materials with high wear resistance, designed specifically for high-end private training; Surface specific double Modal microporous structure, filling particles into the core to form a high-density structure, ensuring resilience and buffering; The bottom increases frictional resistance to prevent the pad from sliding, providing excellent grip performance on both soft and hard surfaces; Seal the cell surface, Prevent sweat from penetrating into the interior and breeding bacteria, durable, hygienic, and easy to clean. Standard hanging holes help with drying and storage after cleaning. Note: Hole spacing 48cm



健身训练垫 FITNESS TRAINING MAT

RSPRO4048

The mat used for fitness training is made of polymer resin combined with a double-layer dense foam structure, which is integrally formed (to some extent, it blocks the propagation of body sound). It is lightweight, tensile resistant, and has better resilience than ordinary mats, providing a certain cushioning effect for joints. The surface adopts curing technology to enhance anti fouling and scratch resistance, and high friction provides good grip. Hanging holes for storage without worrying about creases and odors, it is a special pad for groups/private trainers/beginners.

Note: Hole spacing 48cm
Size: L120 × W60 × T0.8cm
Weight: 1.35kg



椰纤磨砂垫 COCONUT FIBER FROSTED MAT

RSPRO4058

Professional yoga mats incorporate coconut shell fibers to enhance the mat texture, providing a better anti slip feel and solving the embarrassing problem of difficult maintenance. Professional version of posture line, assisting precise posture during practice. 5mm high-density rubber compression provides excellent rebound and support performance. Each layer is designed for a better practice experience (1 coconut shell fiber layer/anti slip and wear-resistant, 2 PU moisture absorbing layer/sweat absorbing and breathable, 3 tear resistant layer/fixed and unchanged deformation, 4 rubber layer/cushioning grip). Melted water material: dries when in contact with water, keeps the surface dry during storage



06

CARDIOPULMONARY ENDURANCE 心肺耐力

IMPROVING BLOOD CIRCULATION

锻炼心肺促进血液循环



手拎平衡盘 BALANCE BOARD WITH HAND GRIPS

RS-PRO4031

Compared to traditional balance discs, it is easy to store, integrated without installation, and has a threaded anti slip surface. To enhance the efficiency of core muscle groups and limb strength, it improves the effectiveness of running, jumping, and throwing events.

Size: H9 × D41.5cm



体感平衡软垫 PU BALANCE PAD

RS-PRO4030

It is made of high-density foam polyester environmental protection material, without irritating smell and harmful substances. Originally used in rehabilitation centers, it later introduced fitness training aimed at balance, stability, and coordinated response training, especially significantly improving ankle rehabilitation and body balance.

Size: L43 × W38 × H6cm



加厚款平衡波速球 THICKENED HALF BALANCE BALL

RS-PRO4029

Thickened balance wave velocity balls help develop and enhance stability and coordination, as well as increase overall activity and functionality, incorporating balance training into many preferred exercises and providing a great functional fitness tool for trainers. This hemisphere is made of durable PVC, with a cross road segmentation and a Chinese retro auspicious cloud anti slip texture. The bottom is made of thick PE and features the brand's iconic black and yellow color scheme.

Size: Q60 × H20cm



高低沙丘踏板 SANDDUNE STEPPER

RS-PRO4013

A unique balance tool that simulates movement training on sand, commonly used for children's sensory integration/motor rehabilitation and challenging core training. This design utilizes two independent platforms that support unilateral training and dynamic movement. This makes it an ideal low impact pedal to help people with ankle, knee, hip, and shoulder injuries recover their health, while also serving as a warm-up product for high-level athletes before competitions.

Size: L66 × W56 × H16cm

Patent number: 202230168691.1



V型功能架 MULTIFUNCTIONAL V RACK

RS-PRO4056

The overall steel frame is designed with an integrated bending and detachable feature, ensuring stable and deformation free connection. Paired with four 5mm NBR sleeves, it enhances anti slip, wear-resistant, and comfortable grip. Suitable for stable support when in the A-shape on the side; Create unstable support when V-shaped on the side; Limit the yoga ball from sliding when in a C-shape on the side.

Size: L58 × W53 × H30cm



足踝康复板 WOBBLE BOARD FOR ANKLE RECOVERY

RS-PRO4046

The correction tool commonly used in rehabilitation centers for eversion of the foot, through effective training in different postures and joint ranges of motion, helps with the rehabilitation of habitual sprains, reduces the possibility of further damage to related areas, and is also a powerful tool for improving 8-shaped and XO shaped legs. Before training, it is necessary to observe the patient's gait, check for arch collapse and other evaluation methods, and then develop relevant ankle joint stability and balance improvement.

Note: The maximum internal and external rotation of the left and right feet is 25°

Size: L30 × W14 × T5cm ∠ 25°



360度平衡盘 360° ROTATION WOODEN TWISTING DISK

RS-PRO4033

Using biomechanical joint angle positioning control to help promote correction of associated muscles and soft tissues, and reduce the risk of intrinsic chronic injury. By using closed chain (CKC) techniques such as shoulder external rotation and internal rotation (provided that closed chain training is performed within 10-30 degrees), joint separation movements such as support/rotation/movement are performed under angle control to reduce joint linkage and promote stable strengthening of the joint capsule and deep muscles.

Size: H4 × 024cm



斜坡甲板 LIMBS OPTIMIZE THE DECK

RS-PRO4047

Combining the specific slope and angle of the deck to solve problems such as poor training skills and center of gravity deviation, in order to better maintain the central axis of the body and improve exercise power output. Especially for people with foot/knee/spine disorders, correcting poor exercise posture, improving and reducing joint pressure. The deck is divided into two parts, left and right. Whether choosing double or single deck, the body can benefit from each repetition (both self weight and weight can be used).

Size: L95 × W60 × H12cm ∠ 12°



智能筋膜枪 TRIGGER POINT RELEASE HAMMER

RSPRO4016

A long-lasting fascia gun that combines ice and fire, with a 3-second rapid cooling and 20 degree constant temperature cold compress, reduces swelling and soreness, and helps the body recover like an ice pack; 5-second rapid heating at 40 degrees Celsius, relieving fatigue and deep muscle relaxation, as comfortable as an egg. Adopting a more suitable 10mm stroke, there will be no numbness in holding hands; Equipped with high-power silent motor and Type-C connector, 5 types of massage heads for different muscles, not easily damaged.

Reminder: Please read the instruction manual carefully before use.

编号	颜色	尺寸
RSPRO4016-01		L23 × W22 × H9cm
RSPRO4016-02		L23 × W22 × H9cm



穴位按摩器 ACUPPOINT MASSAGE

RSPRO4052

Ergonomic lightweight design allows you to apply deep pressure to muscles within reach. It is an ideal tool for clinic or home use, which can apply firm and sustained pressure to the target muscles. Regular use helps maintain muscle relaxation, eliminate muscle nodules, and reduce the risk of injury. Recommended for use by physical therapists, massage therapists, or individuals, especially for those who sit for long periods of time, with better results before and after exercise.

Size: L17 × W9.7 × Q2.88cm



S型自主按摩钩 MASSAGER HOOK

RSPRO4012

Made from imported polymer materials, the massage hook can help trigger deep tissue massage at pain points. The circular knob simulates the movement of a massage rehabilitation therapist's thumb, and with the help of a special handle and lever principle, only a little force is needed to touch the tight muscles of the entire body. It is a new favorite artifact that does not require anyone.

Size: L60 × W27cm



普拉提环 PILATES RING

RSPRO4025

The official name of the Pilates ring should be "Resistance Ring". Made of high elasticity fiberglass. It doesn't look particularly special

However, when added to Pilates, it immediately makes the training more challenging, increases the instability factors during training, and thus achieves twice the result with half the effort. (Press down to 11kg force)

Size: 038cm

Weight: 0.3kg

普拉提球 PILATES BALL

RSPRO4023

The lightweight and easy to grip spherical surface is perfect for Pilates exercises, allowing for various exercises with varying degrees of assistance and resistance. Commonly used for isometric maintenance, leg and abdominal exercises, and as a core training aid tool. These balls can be used for all age groups.



编号	规格	颜色	尺寸
RSPRO4023-01	110G		直径20cm
RSPRO4023-02	150G		直径25cm
RSPRO4023-03	200G		直径30cm



花生球 PEANUT EXERCISE BALL

RSPRO4027

The peanut shape ensures that the ball only moves on one plane. Very suitable for beginners, children, or the elderly, and also an ideal choice for managing rehabilitation.

The explosion-proof rating is 200 kilograms.



苹果球 APPLE SHAPE YOGA BALL

RSPRO4026

A super durable and burst resistant sports ball. Doughnuts are not only used for abdominal exercises, but also as a tool for stability and balance training. Through a series of balance and stability exercises, they strengthen the strength and endurance of the core muscle group, which is more effective than a single exercise

Lying on your back is more effective.

The explosion-proof rating is 200 kilograms.



瑞士球 SWISS BALL

RSPRO4026

By continuously targeting the core and back muscles to improve strength and balance, it helps elevate sit ups, side bridges, and stretches to a new level, thereby establishing stable muscles and increasing flexibility. Suitable for rehabilitation, warm-up, and stability training, it helps to train and establish stable muscles required for functional strength and athletic performance.

The explosion-proof rating is 200 kilograms.

编号	规格	尺寸
RSPRO4026-01	900G/炭黑	Ø55cm/155-170cm
RSPRO4026-02	1000G/炭黑	Ø65cm/170-185cm
RSPRO4026-03	1200G/炭黑	Ø75cm/185cm+
RSPRO4027	1300g	L90 × Ø45cm
RSPRO4028	1000g	Ø45 × H25cm



迷彩花生球 CAMO PEANUT MASSAGE BALL

RSPRO4041

You understand your pressing ball better than your fingers, and it is an excellent massage tool for areas that are difficult to reach, especially for the thoracic spine, shoulders, neck, buttocks, calves, and soles of the feet. The surface of the ball is designed with stripes and raised grids, which can relieve the soreness of the target muscle group when rolling. It has better effect than a flat ball, is more comfortable than a pointed ball, and is larger in size than a regular ball. EVA material has fast rebound speed and is not easily deformed, helping you accelerate body recovery and improve flexibility. Size: L20 × Ø 11cm Weight: 260g



迷彩筋膜球 CAMO MASSAGE BALL

RSPRO4042

You understand your pressing ball better than your fingers, and it is an excellent massage tool for areas that are difficult to reach, especially for the thoracic spine, shoulders, neck, buttocks, calves, and soles of the feet. The surface of the ball is designed with stripes and raised grids, which can relieve the soreness of the target muscle group when rolling. It has better effect than a flat ball, is more comfortable than a pointed ball, and is larger in size than a regular ball. EVA material has fast rebound speed and is not easily deformed, helping you accelerate body recovery and improve flexibility. Size: Ø13cm Weight: 215g



吸盘放松球 SUCTION CUP FASCIA BALL

RSPRO4008

Adsorption relaxation ball, scientifically massages and targets fatigue, designed ergonomically to achieve acupoint and meridian massage. The silicone material has a small volume and is extremely convenient to carry when traveling or frequently changing fitness venues. Press it in your spare time, and you'll feel refreshed immediately! The whole body can be used, and it can soothe more than one part.

颜色	尺寸
RSPRO4008-01	L7.5 × Ø6.2cm
RSPRO4008-02	L7.5 × Ø6.2cm
RSPRO4008-03	L7.5 × Ø6.2cm
RSPRO4008-04	L7.5 × Ø6.2cm
RSPRO4008-05	L7.5 × Ø6.2cm



脊柱按摩棍 SPINES SPINE MASSAGE STICK

RSPRO4045

Spinal massage stick is developed based on treatment practice and the daily work needs of coaches, widely used in private teaching and group training teaching. Due to its unique shape, it is commonly known as a "caterpillar", with 28 balls on one side providing mechanical stimulation to the muscles on both sides of the spine, producing a strong massage effect (double-sided spheres are the same in shape). It can also innovate training and exercise sequences to enhance the body's perception ability, providing diverse/effective solutions. Size: L82.5 × W12 × H6cm



12位伸展带 YOGA STRETCH STRAP-12M

RSPRO4017

A comfortable 12 position buckle designed specifically for grasping or placing feet, which can assist in achieving deeper and more effective stretching, improving muscle adhesion, and relieving muscle tension and tightness. Micro elastic fabric increases flexibility without excessively stretching muscles and tendons, improving athletic performance and rehabilitation training without exacerbating injuries. Attention: Before each training session, carefully check the wear and tear condition. Size: L220 × W3.5cm



螺旋链训练带 SPIRAL TRAINING STRAP

RSPRO4018

A strap specifically designed for spiral chain training, which increases rotational strength and improves flexibility. Using this training strap can help improve the power chain. Innovative design makes the rehabilitation and capacity enhancement process easier and more efficient. Attention: Before each training session, carefully check the wear and tear condition. Size: L150 × W5cm



瑜伽垫便携绑带 YOGA PORTABLE BANDAGE

RSPRO4039

Simplify your life and practice with this innovative design of 2-in-1 yoga belt and cushion strap. Durable Made from compliant and environmentally friendly cannabis, it has the strength and flexibility required to deepen posture and enhance stretching without harming oneself. Size: L200 × W5cm



瑜伽砖 YOGA BLOCK

RSPRO4020

High density EVA biodegradable environmentally friendly material, integrated closed cell foam, surface sandblasting treatment, making the practitioner unforgettable the strong adsorption feeling. Adopting the mobile phone edge arc cutting technology, the overall look is more elegant and agile, providing a comfortable and snug grip (± 20g). Size: L23 × W15 × H7.5cm Specification: Black 0.3kg



OOV版脊柱矫正 ARC SPINE CORRECTOR

RSPRO4024

Through unbalanced design, amplifying the problems in the body during training, guiding spontaneous activation of the core, unlocking biofeedback and body self-regulation functions. Effectively discover the body's compensatory mechanisms and intelligently activate the search for deep muscles to achieve balance in an unbalanced state. Activate the core while maximizing joint flexibility. Extend training to programs such as Pilates/yoga. Size: S size L64 × W26 × H16cm M size L67 × W29 × H17cm



ARC版脊柱矫正 ARC SPINE CORRECTOR

RSPRO4022

A R C version spinal correction A R E S P I N E C D R E T D R The ARC version spinal corrector does not contain any harmful chemicals and is a commonly used tool in Pilates. It can be used for RS R 40 training, rehabilitation training, correcting the spine, correcting bones, stretching the back, and relieving back pain, while correcting and restoring the natural curvature of the spine. Size: L102 × W30 × H42cm



05

运动恢复 REHAB & REBUILD

ESSENTIAL FUNCTIONAL TRAINING TOOLS FOR HEALTH IMPROVEMENT

重塑健康的重要小工具

BRRATHING



RR款滚轴 MASSAGE ROLLER-RR

RSPRO4002

Integrated molding, water droplet floating point, more conducive to the pressing and elimination of the trigger point. The staggered massage of large and small floating points leaves no dead corners, deeply destroying muscle adhesion phenomenon. Every part can withstand the test and is not afraid of heavy weight pressure, making muscles sore but not dead Stimulating.
Size: L45 × Q14cm



TP款滚轴 MASSAGE ROLLER-TP

RSPRO4001

Biomimetic 3D partition design (fingertips, fingers, palms) with three human massage sensations, hollow, lightweight and practical, easy to carry for daily fitness, relieving physical fatigue/pain/injury during exercise and life, greatly improving quality of life and sports performance.

编号	颜色	重量	尺寸
RSPRO4001-01	黄色	0.7kg	L33 × Ø14cm
RSPRO4001-02	黑色	0.7kg	L33 × Ø14cm



高架滚轴 ELEVATED FOAM ROLLER

RSPRO4043

The ergonomic foam roller covers a wider area than the traditional foam roller, and its ingenious design ensures that it stays still during rolling. The sturdy and adjustable support legs can be set in three variations (raised/angled/lowered), which is more conducive to muscle groups that are difficult to reach throughout the body, solving the problem of incomplete relaxation caused by insufficient arm support, such as the calves, limbs, and buttocks. In addition, the elevated setting allows for one leg Roman squat, which helps to innovate more training and training functions.
Patent number: 2023200463991

编号	颜色	重量	尺寸
RSPRO4043-01	黑色	5.15kg	L56 × W45 × L44cm
RSPRO4043-02	红色	5.15kg	L56 × W45 × L44cm



球形沙袋 BALL SHAPED PUNCHING BAG

RSPRO3010

Spherical sandbags are designed to prevent the impact of hook punches from being too deep when there is no target player (in actual combat, the target is the opponent's chin). When the center height of the sandbag is selected to be basically the same as the opponent's head, it can effectively train and optimize the hitting rhythm and increase strength, strengthen the fluency of combination punches, and ensure that each punch is hit with the maximum power it should have.

Size: H80 × D60cm
Weight: 36kg



泪珠沙袋 TEARDROP BOXING SANDBAG

RSPRO3014

The teardrop sandbag is made of extremely sturdy and durable leather, with a unique shape that can develop and perfect agility. If you want to develop close combat skills and everything in between, this is the best choice. The shape and design of the teardrop can be freely adjusted in height position, which is more convenient than large sandbags. The device focuses on durability, which will take you to the best state.

Size: H92 × ① 46cm
Weight: 29kg

立式沙袋 STANDING PUNCHING BAG

RSPRO3016

Vertical sandbags provide high-density foam filler and round durable vinyl base (filled with sand or water), with uniform weight and high stability, weighing 80-100kg after filling. No need for brackets or wall installations. used for

Speed and technique training are very popular in applications such as karate, taekwondo, Muay Thai, boxing, and taekwondo. Very suitable for indoor/outdoor use, creating fun workouts for the entire family.

Attention: This base needs to be filled by yourself, and it is recommended to fill it with yellow sand/silt water, etc

Size: H140 × Q38cm H40 × ① 60cm
Weight: 100kg sand/80kg water



吊式沙袋 HANGING BOXING SANDBAG

RSPRO3015

Hanging sandbags are required for boxing, Muay Thai, or MMA training. Nylon sling reduces the noise caused by shaking and avoids rusting of iron chains. It has a simple and convenient invisible zipper seal, a sturdy willow nail reinforced connecting strap, and a tight and smooth overall wiring, greatly enhancing its service life. Specially designed for gyms/studios, made of sturdy and durable nylon that can last for a long time and repeat punches. Practice your punches, cross hooks, straight kicks, and round kicks while achieving outstanding performance in the process. Whether combined with fitness training programs, excellent boxing athletes, or as a tool for exercising health, it is a great way to improve skills, strength, and endurance. Filled with textile scraps of different weights and sizes, the weight of the sandbag is balanced.

编号	规格	尺寸
RSPRO3015-01	40kg	H140 × Ø35cm
RSPRO3015-02	50kg	H180 × Ø35cm



陪练腰靶 WAIST TARGET

RSPRO3003

The lightweight waist target is covered with high-quality and synthetic leather, and the lightweight shape is injected with multi-layer foam to provide heavy protection. At the same time, the training is heavy and free, and the three-point target is accurate; The oversized Velcro is stable and fits different body shapes, suitable for forward/side strikes/protection, etc.

Size: 35 × 6 × upper W21/lower W18cm



胫骨护具 BOXING SHIN GUARDS

RSPRO3009

The open design of the shin guard and instep guard fundamentally reduces the risk of injury to the shin guard and instep. The high-density composite sponge is shock-absorbing and reduces stress, dispersing the impact force. The lining is made of non slip denim fabric, and the metal free and flexible Velcro buckle is easy to adjust and remove, making it suitable for hitting practice.

Size: L42 × W12cm



横梁头盔 BOXING HEADGEAR

RSPRO3004

The wear-resistant leather seal provides durability and service life. The dense multi-layer four sponge foam package makes the interior soft and comfortable. The top cross is breathable and does not shift, and the molded fastener is stable and does not fall off; Complete ear filling coverage, leather chin and cheekbone protection design, not only safe and comfortable, but also easier to wipe clean after use, suitable for training and practical combat such as Sanda/Borussia/Boxing. Size: Head circumference 55-57cm



敏捷棒 AGILITY BAR

RSPRO3012

The lightweight waist target is covered with high-quality and synthetic leather, and the lightweight shape is injected with multi-layer foam to provide heavy protection. At the same time, the training is heavy and free, and the three-point target is accurate; The oversized Velcro is stable and fits different body shapes, suitable for forward/side strikes/protection, etc.

Size: 35 × 6 × upper W21/lower W18cm



搏击踢靶 BOXING KICKING PAD

RSPRO3005

High quality super fiber leather with dense foam filling. The front hip pad provides support and protection for training; Dense foam blocks leg/elbow and knee attacks; Velcro is designed to be easy to pick up and suitable for various groups of people, including boxing, Muay Thai, and daily training.

Size: 35 × 21/18 × 6cm

Weight: 2kg



重型腿靶 BOXING LEG TARGET

RSPRO3007

Lining fabric made of 100% polyester fiber; Liner 50% PE+50% polyester fiber, high-density foam to absorb knee kick; High quality leather, durable and resistant to impact; Willow nail+cushioned handle, resistant to impact and ensuring firm grip, suitable for professional use in Sanda/Boxing/Fighting.

Size: 035 × T10cm/L25cm

Weight: 0.5kg



速度手靶 BOXING MITTS

RSPRO3006

RSPRO3006 High quality microfiber leather, PE/EVA inner liner, mesh ensures ventilation and heat dissipation; Strengthening the hit resistance of hand targets with thick thread locking edges; The high elasticity inner liner provides excellent cushioning effect, suitable for boxing/sanda/combat, etc.

Size: L35 × W18 × T6cm

Weight: 0.5kg



乒乓球靶 PINGPANG PUNCHING PADS

RSPRO3008

High quality microfiber leather, high-density EVA inner panel. The non slip grip does not come off, making training more efficient; High elasticity and elastic wrist binding, not tight on the hands, suitable for boxing training, improving accuracy and reaction speed, etc.

Size: 037 × 18 × 3.5cm

Weight: 0.5kg



五层储物架 FIVE LAYER STORAGE RACK

RSPRO5014

Adopting a compact design and occupying less space, it is one of the commonly used storage racks in the industry. The bottom layer is suitable for balanced hemisphere/competitive barbell plates, the second and third layers are suitable for kettlebells/rollers/yoga bricks, etc., and the fourth and fifth layers are used for storing medicinal balls/wall balls and stabilizing balls. Both sides are equipped with barbell suspension hooks, suitable for hanging barbell rods/resistance bands and elastic tubes. If needed, they can be disassembled (refer to the storage diagram).

Attention: Only sold as a rack, not including layer products
Size: L158 × W78 × H205cm
Weight: 66kg

组合置物架 MODULAR STORAGE RACK

RSPRO5012

This is a powerful small storage rack that not only stores a large number of tools but is also versatile, made of pure steel. There are 10 storage compartments on both sides, which can hold tools such as medicine balls, wall balls, Bulgarian bags, energy packs, etc; The front and back can be used to hang training mats/skipping ropes/elastic bands and other tools; There are also two layers of pallets at the bottom for placing items such as fascia balls or foam rollers (the maximum capacity of a single layer is 10 rollers).

Attention: Only sold as a rack, not including layer products
Size: 165 × 77.5 × 200cm
Weight: 63kg



训练垫挂架 YOGA MAT STANDING RACK

RSPRO5009

Hanging mat rack is an ideal choice to reduce mat wear and maintain cleanliness. The hook width can be adjusted to fit all mats, and it can be hung on both sides. It is equipped with 2 double-sided hooks and 2 single-sided hooks, with a maximum hanging length of 180cm for 20 sheets. Tools such as elastic bands and jump ropes can also be selected for hanging.

Attention: Only sold as a rack, not including layer products
Size: L77.5 × W113 × H184.5cm
Weight: 17.7kg



立式工具架 VERTICAL RACK FOR MEDICINE BALLS/POWER BAGS

RSPRO5007

The accompanying set of 10 storage trees comes with 2mm thick steel pipes, support rods to showcase each ball, and floor feet to prevent wear and make the training area more professional. Made by welding and assembling round and sturdy pipes; Black spray coating on the surface.

Attention: Only sold as a rack, not including layer products
Size: 77.5 × 73 × 199.5cm
Weight: 29kg



瑜伽垫收纳架 YOGA MAT HOLDER

RSPRO5013

The storage rack neatly combines cushions/rollers to save space and prevent water and moisture within one square meter, bidding farewell to the clutter of the venue. Preferred thickened pipe with precision welding for stable structure; Bottom anti slip foot pad to prevent damage to the floor during movement; Make the venue orderly and secure (with a maximum capacity of 42 standard mats).

Attention: Only sold as a rack, not including layer products
Size: 78 × 73 × 180cm
Weight: 50kg



立式哑铃架 VERTICAL DUMBBELL RACK FOR 1-10KG DUMBBELLS

RSPRO5004

The upright dumbbell stand is made of high-quality black laser cutting and color powder coating (10 pairs of small dumbbells). The stand is compatible with any commercial facility or home gym, with high stability and small footprint. This space saving design comfortably fixes 10 pairs of hexagonal dumbbells in smooth slots.

Attention: Only sold as a rack, not including layer products
Size: 77.5 × 73 × 147cm
Weight: 32.2kg



CF195 多功能全框深蹲架
CF195 POWER RACK WITH MOB LIE HANDLES

R inch/size: 1850 * 1250 * 2350mm
 Tube: 75x75 * 3mm
 Features: Laser cutting triangular fastening plate; Bearing mobile pull handle;
 Accessories IAc ceso ries: 1 set * barbell hook, 1 set * safety arm, 1 piece * barrel color I color: matte black, red, blue, yellow (see color card p19 for details)



CF196 多功能半框深蹲架
CF196 HALF POWER RACK

Size/size: 1450 * 1250 * 2350mm
 Tube: 75x75 * 3mm
 Features: Laser cutting triangular fastening plate; Multi functional six way handle;
 Accessories IAc ceso ries: 1 set * barbell hook, 1 set * safety arm, 1 piece * barrel color I color: matte black, red, blue, yellow (see color card p19 for details)



CF199 全框推胸深蹲架带飞行臂
CF199 POWER RACK WITH CHEST PRESS & FLYING CHIN-UP

Size/size: 2050 * 1250 * 2350mm
 Tube: 75x75 * 3mm
 Features: Multi functional six way handle; Equipped with chest push arm and pull-up flying frame;
 Accessories IAc ceso ries: 1 set * barbell hook, 1 set * safety arm, 1 piece * barrel color I color: matte black, red, blue, yellow (see color card p19 for details)



CF200 新半框深蹲架
CF200 NEW HALF POWER RACK

Size/size: 1450 * 1250 * 2350mm
 Tube: 75x75 * 3mm
 Features: Laser cutting triangular fastening plate; Multi functional six way handle;
 Accessories IAc ceso ries: 1 set * barbell hook, 1 set * safety arm, 1 piece * barrel color I color: matte black, red, blue, yellow (see color card p19 for details)



CF198 全框深蹲架
CF198 FULL POWER RACK

Size/size: 1850 * 1250 * 2400mm
 Pipe/Tube: 75x75 * 3mm
 Features: Laser engraved logo board, multi angle pull handle;
 Accessories/Acc eso ries: 1 set * barbell hook, 1 set * safety arm, 1 set * safety belt color I color: matte black, red, blue, yellow (see color card p19 for details)



CF197 半框深蹲架
CF197 HALF POWER RACK

Size/size: 1450 * 1250 * 2400 mm
 Tube: 75x75 * 3mm
 Features: Laser engraved logo board, multi angle pull handle;
 Accessories IAc ceso ries: 1 set * barbell hook, 1 set * safety arm
 Color I: Matte black, red, blue, yellow (see color chart p19 for details)



CF150 简易深蹲架 (带引体杆)
CF150 SQUAT RACK WITH CHIN-UP BAR

Size/Size: 1250 * 1250 * 2250mm
Pipe/Tube: 60x60; 70x70 or 75x75*3mm;
Features: Laser cut triangular fastening plate, M16 electroplated anti loosening bolt
accessories/Accessories: 1 pair * barbell hook, 1 pair * safety arm



CF148 简易深蹲架
CF148 SIMPLE SQUAT RACK

Size/Size: 1250 * 1250 * 2250mm
Pipe/Tube: 60 * 60; 70x70 or 75x75*3mm;
Accessories: 1 set of barbell hooks, 1 set of safety arms



CF146 独立深蹲架
CF146 INDEPENDENT SQUAT RACK

Size/Size: 650 * 600 * 1800mm
Pipe/Tube: 60x60; 70x70 or 75x75*3mm;
Accessories: 1 set of barbell hooks, 1 set of safety arms





CF191H 专业半框深蹲架
CF191H PRO HALF POWER RACK

Size/size: 1250 * 1250 * 2400mm
 Tube: 75x75 * 3mm
 Features: Laser engraved logo board, multi-layer scratch resistant spray painted paint; 8mm stamped parts; M20 electroplated anti loosening bolt accessories IAc ceso ries: 1 pair * barbell hook, 1 pair * safety bar
 Color/I color: Matte black, red, blue, yellow (see color chart p20 for details)



CF191 专业深蹲架
CF191H PRO POWER RACK



KF6000F 全框深蹲史密斯
SMITH POWER RACK

Size/size: 1850 * 1250 * 2350mm
 Tube: 75x75 * 3mm
 Features: Laser cutting triangular fastening plate; Six way or mobile pull handle; 30mm diameter stainless steel guide rod, equipped with four bearing Smith sleeve accessories/Acc ESO ries: 1 set * barbell hook, 1 set * safety arm, 1 set * cannon barrel color/I color: frosted black, white, red, yellow (see color card p20 for details)



CF191F 专业全框深蹲架
CF191F PRO FULL POWER RACK

R inch/size: 1850 * 1250 * 2400mm
 Tube: 75x75 * 3mm
 Features: Laser engraved logo board, multi-layer scratch resistant spray painted paint; 8mm stamped parts; M20 electroplated anti loosening bolt accessories IAc ceso ries: 1 pair * barbell hook, 1 pair * seat belt
 Color I: Matte black, red, blue, yellow (see color chart p20 for details)



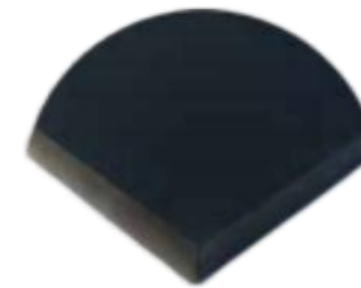
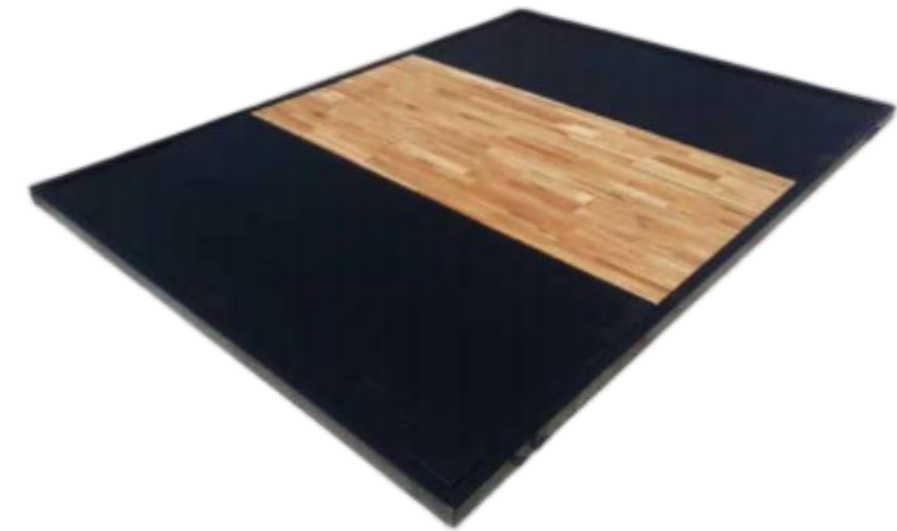

CF 201 专业举重台

OLYMPIC WEIGHTLIFTING PLATFORM

Size: 2800 * 1800 * 50mm, 2000X3000X50
3000*3000*50mm, 4000x4000x50

Features/FEATURE Russian imported water chestnut solid wood board, impact resistant, non cracking, non warping 100% high-quality natural rubber pad, no odor, excellent cushioning performance, no debris falling off, High strength steel frame, multi-layer anti spray paint, laser cutting corner protection connection.

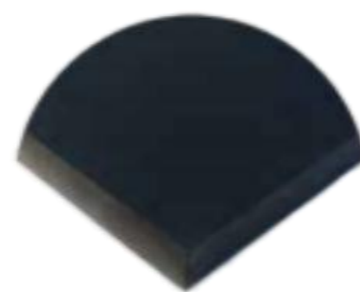

CF 206 八角举重台

Size/SIZE: 2450 * 1800 * 30mm
Features: High temperature pressed multi-layer staggered solid wood panel, impact resistant, non cracking, and not prone to warping; High quality rubber cushion, odorless, impact resistant, and does not shed debris; Steel frame, multi-layer anti spray paint, laser cut octagonal edge protection.

CF 202 训练举重台

WEIGHTLIFTING PLATFORM

Size/SIZE: 2450 * 1800 * 30mm
Features: High temperature pressed multi-layer staggered solid wood panel, impact resistant, non cracking, and not prone to warping; High quality rubber cushion, odorless, impact resistant, and does not shed debris; Steel frame, multi-layer anti spray paint, laser cutting corner protection connection.



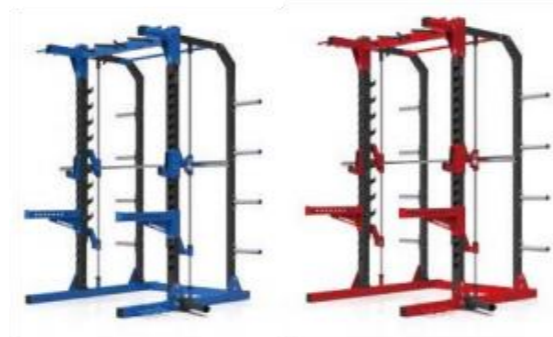

KF6000H 半框深蹲史密斯
HALF SMITH POWER RACK

Size/size: 1450 * 1250 * 2350mm
Pipe/Tube: 75x75 * 3mm
Features: Laser cutting triangular fastening plate; Six way or mobile pull handle;
30mm diameter stainless steel guide rod, equipped with four bearing Smith sleeve accessories/Acc ESO ries: 1 set * barbell hook, 1 set * safety arm, 1 set * cannon barrel
color I color: matte black, white, red, yellow (see color card p20 for details)



KF9000 多功能综合训练器
MULT I-FUNCTIONAL TRAINER

Instrument size/size: 1250 ** 1250 * 2250;
Weight: 75KG (optional 9KG) * 2, a total of 150KG
Tube specifications: 75x75 * 3mm precision tube;
Accessories/Acc eso ries: 1 set of barbell hooks, 1 set of safety arms, 1 high pull seat, 1 low pull foot flare, 1 set of high and low pull five piece set
Color I: Matte black, white, red, yellow (see color chart p20 for details)



KF8000多功能史密斯
SMITH POWER RACK

Low profile Lin Shi, powerful functionality! Suitable for both studio and home use.
A device that can perform functions such as squats, bench presses, combos, free flying birds, and high and low pulls;
Instrument size/size: 1350 ** 1250 * 2250; counterweight: 75KG * 2, a total of 150KG; pipe specifications/Tube: 60x80 * 3mm precision tube; 60 * 60 * 2.5mm stainless steel pipe fittings IAc ceso ries: 1 pair * barbell hook, 1 pair * safety arm, 2 * handles
Color I: Matte black, white, red, yellow (see color chart p20 for details)



KF3000系列 高低拉训练器
LAT PULL DOWN ROWING MACHINE

High pull down, low pull rowing, compact structure, no space occupation.
Instrument size: 1250 * 1050 * 2400, counterweight: 90KG * 1
Tube specifications: 75x75 * 3mm precision tube;
Accessories/Acc eso ries: 1 * high floor pull up seat, 1 set * high and low pull up five piece set
Color I: matte black, white, red, yellow (see color card p20 for details)



KF1000A 多功能组合训练架
SUPER-X CROSS MAX RACK

Instrument size/size: 3150 * 1250 * 2400;
Weight: 75KG * 2 pipe specifications/Tube: 75 * 75 * 3mm
Features: Equipped with bearing sliding pull handle and chest arm
Accessories: 1 set of barbell hooks, 1 set of safety arms, 2 sets of handle colors/Color: matte black, white, red, yellow (see color card P20 for details)



KF1000E 多功能组合训练架
SUPER-X CROSS MAX RACK

Function implementation: deep squat bench press, double arm chest push, double arm flying bird, high back pull, low pull rowing
Pull up, core training, etc;
Instrument size/size: 4800 * 1250 * 2400; Weight: 75KG * 2
Pipe specifications/Tube: 75 * 75 * 3mm
Features: The middle storage function includes an Olympic pole insertion and a bell blade insertion, which can achieve dual arm flying bird and chest pushing functions. Accessories: 1 set of barbell hooks, 1 set of chest push arms, 2 handles
Color/Color: Matte black, white, red, yellow (see color chart P20 for details)



KF1000B 多功能组合训练架
SUPER-X CROSS MAX RACK

Instrument size/size: 3150 * 1250 * 2400; Weight: 75KG * 2
Pipe specifications/Tube: 75 * 75 * 3mm
Features: Equipped with pull-up bars and chest pushing arms
Accessories: 1 set of barbell hooks, 1 set of chest push arms, 2 sets of handle colors/Color: matte black, white, red, yellow (see color card P20 for details)



KF1000F 多功能组合训练架
SUPER-X CROSS MAX RACK

Function implementation: deep squat bench press, double arm chest push, double arm flying bird, high pull back, low pull rowing, pull up, core training, etc;
Instrument size/size: 4500 * 1250 * 2400; Weight: 75KG * 3 sets, totaling 225kg
Pipe specifications/Tube: 75 * 75 * 3mm
Features: The middle storage function has a bell blade insertion rod, which can achieve dual arm flying bird and chest pushing functions. Accessories: 1 set of barbell hooks, 1 set of chest push arms, 2 handles
Color/Color: Matte black, white, red, yellow (see color chart P20 for details)



CMFS Functional Training System

CMFS 功能性训练系统



CF1000 CMFS 功能性训练架系统 (双排云梯)
FUNCTIONAL TRAINING RACK SYSTEM

Size/SIZE: 4500*4500*450 mm, 4500*6000*2450 mm
6000*4500*2450mm, 6000*6000*2450 mm +
TUBE: 80x160x3mm, 100x200x3mm
dot color/COLOR: pink black, classical 32418, pink white, space grey
Quality/FEATURE: high-temperature intensity cut; Highlight 23618;
21943; brown
Many functionality groups, free team development,
ACCESSORIES:
We need to take a two-way climb up the stairs, pull the trigger up,
go to 24748, pull the unit, pull the machine.
Optional: Auxiliary wooden frame, flying arm, core barrel, curved
arm support, jumping platform, laser engraved logo board

2.0 CMFS 功能训练站 CMFS Function training station



CF1000 CMFS功能性训练架系统 (单排云梯)
FUNCTIONAL TRAINING RACK SYSTEM

Comprehensive upgrade
Higher quality Perfect compatibility

The CMFS functional training system, with its comprehensive functionality, covering multiple training storage and other functions; Flexible customization of color and size training programs, making them suitable for venues of any style and size. Good compatibility is the preferred equipment for creating high-end fitness studios.

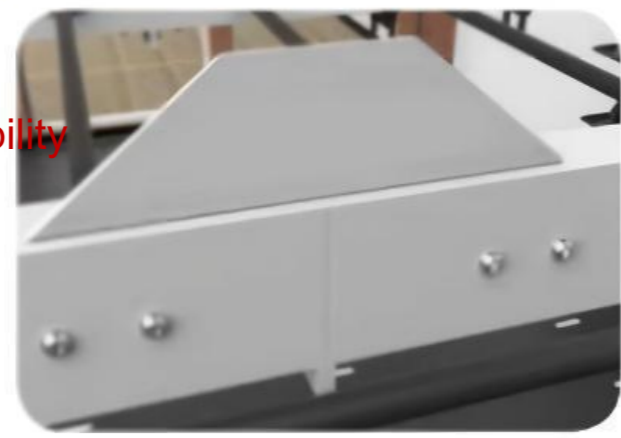

Size/SIZE: 4800*4500*450 mm, 4800*5000*2450 mm, 4800*6000*2450 mm, 5000*6000*2450 mm
Material/TUBE: 80X160X3mm, 100x200x3mm
dot color/COLOR: pink black, classical 32418, pink white, space grey



CMFS墙角式功能储物架系统

Effectively utilize indoor wall corner space and design a unique comprehensive training rack system that combines training and storage functions

Customized venue exclusive logo board, both R-
inch and storage function configurations can be customized



CF700-355 C MFS墙角式功能储物架
CMFS FUNCTIONAL STORAGE CORNER RACK

Size/SIZE: 2150 * 2150 * 2450mm
Pipe/TUBE: 80 × 160X3mm,
Features/FUTURE: High precision laser cutting;
High gloss multi-layer spray paint color/COLOR:
matte black, elegant red, pearl white, space gray



CF700-215 C MFS墙角式功能储物架
CMFS FUNCTIONAL STORAGE CORNER RACK

Size/SIZE: 3550 * 2150 * 2450mm,
Pipe/TUBE: 80X160X3mm,
Features/FUTURE: High precision laser cutting;
High gloss multi-layer spray paint color/COLOR:
matte black, elegant red, pearl white, space gray

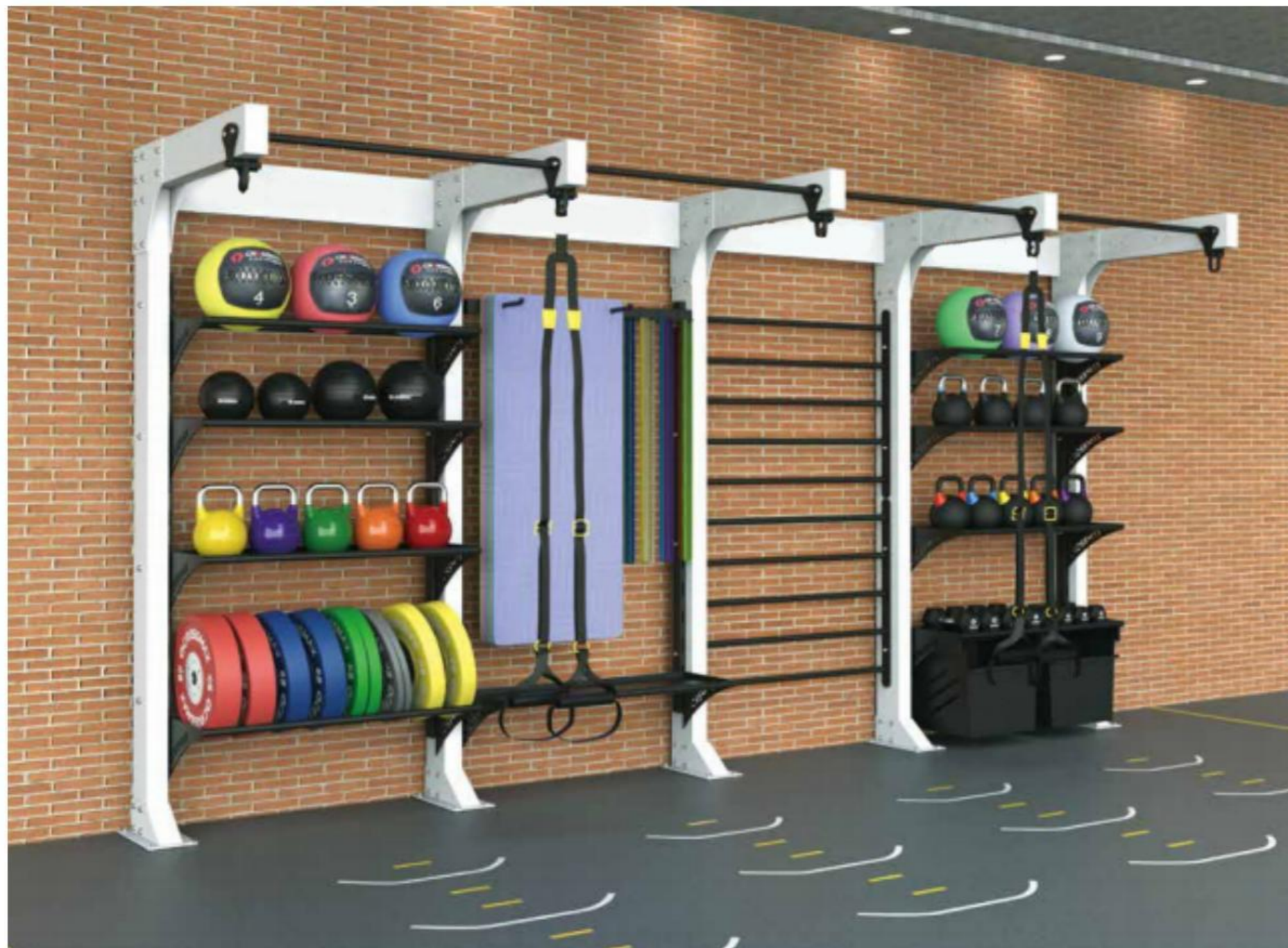

CF600 CMFS 墙壁式功能储物架
CMFS WALL FUNCTIONAL STORAGE RACK

Size/Dimensions: 1500 * 900 * 2450mm; 3000 * 900 * 2450mm;

4500 * 900 * 2450mm; 6000 * 900 * 2450mm, pipe/tube: 80X160X3mm,

Features: High precision laser cutting; High gloss multi-layer spray paint

Multiple functional components that can be freely combined and expanded

Color/Color: Matte Black, Elegant Red, Pearl White, Space Grey

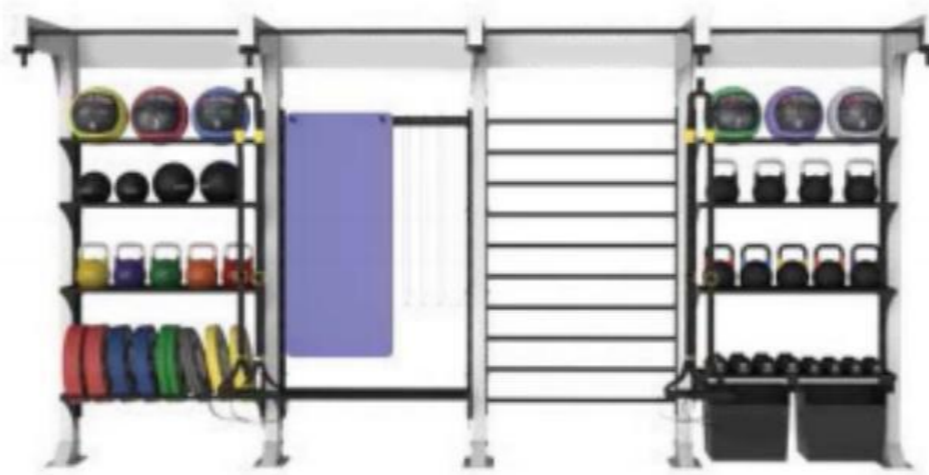

CRX Functional Ring G cage CRX功能擂台

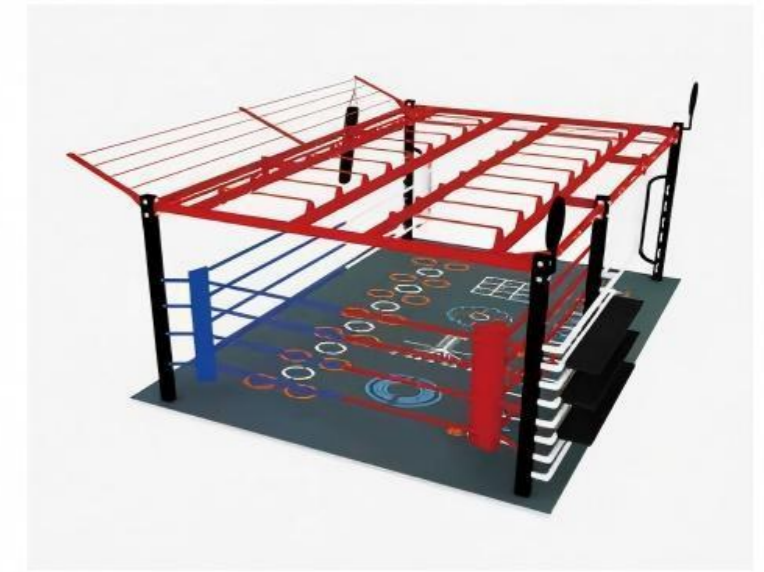
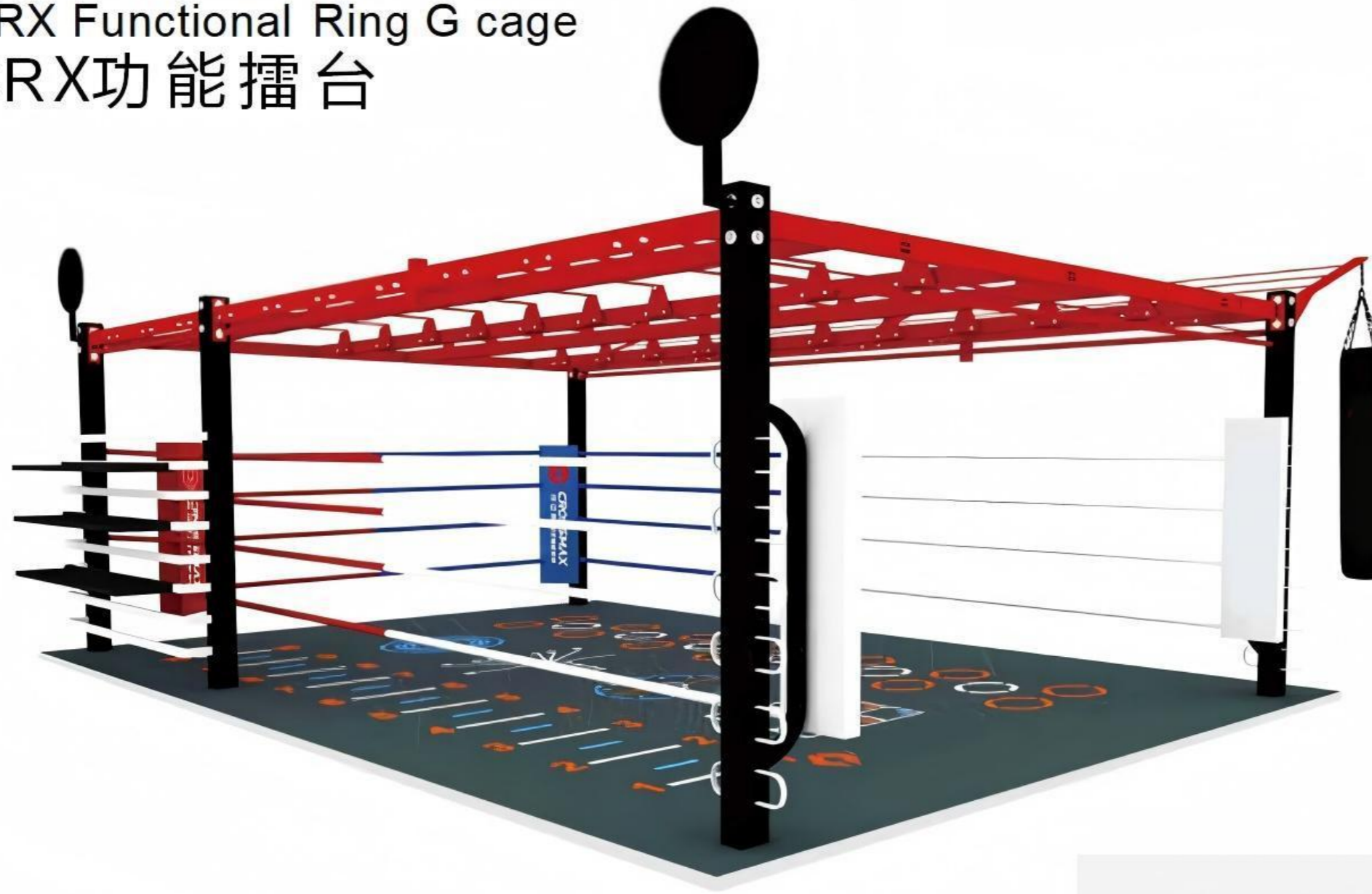

CF800 功能性拳台 CRX FUNCTIONAL RING & CAGE

Size/SIZE: 4m*4m; 4.5m*4.5m; 4m*6m; 4.5m*6m
 高度/HEIGHT: 2350mm/3250mm ;
 Material/TUBE: 100×100×4mm, 60x80x3mm
 dot color/COLOR: pink black, pink 32418, pink white, space grey
 Property/FEATURE: default fiscal 20987;+ 25794;+ placement, 30422;+ printing function 35757x;+ 32451x;+ images Many functionality groups are free to develop high-energy energy energy,
 Cut; height 26723; anti-21038; brush; color and size can be determined; dishes/ACCESSORIES: (Tape 35814;)



CF178 多功能综合储物架
CF178 MULTI STORAGE RACK

Size/SIZE: 4000 * 420 * 1800 mm
 Pipe/TUBE: 60x80x3mm
 Features/FEATURE: First layer barbell plate insertion rack; Second layer kettle bell shelf; Third layer dumbbell shelf; Fourth layer medicine ball/wall ball shelf; Middle suspension bracket (resistance band, yoga mat, elastic rope) Remarks: Color and size can be customized.



CF178P 新款综合储物架
CF178P NEW MULTI STORAGE RACK

Size/SIZE: 1800/3600/4800 * 420 * 1800mm
 Pipe/TUBE: 60x80x3mm
 Features: Laser engraved logo side panel connection; The first layer of kettle bell shelf; Second layer kettle bell shelf; Third layer dumbbell shelf; The fourth layer of medicine ball/gravity ball shelf; Fifth layer wall ball parallel bars; Hanging brackets (yoga mats, resistance bands, elastic ropes) can be added between two groups. Note: Colors and sizes can be customized.



Storage Rack
综合置物架



CF179 新式大型综合储物架
CF179 PRO X-STORAGE RACK

SIZE: 1800 * 420 * 1800 mm

TUBE: 75×75×3mm

Features: First set of small dumbbells and tension bands; The second group includes wave velocity balls, kettlebells, and medicinal balls; The third set of rhythmic pedals; Top floor: fitness ball, sides: yoga mat, small pendant

Note: Color and size can be customized.



CF138 平衡球架
CF138 GYM BALL RACK

Size/SIZE: 650 * 750 * 120mm, 28kg
Features/FUTURE: Made of high-quality carbon structural steel, with a 5-layer design



CF119 九孔奥杆插座
CF119 OLYMPIC BAR HOLDER



CF120 壁挂式奥杆挂架
CF102 WALL MOUNTED BAR RACK



CF103 插式铃片推车
CF03 PLATES TR ELLE Y



CF102 串式铃片推车
CF102 PLATES TR ELLE Y

备注: 颜色和尺寸可定制。



CF175 工作室爆款储物架
CF175 STUDIO STORAGE RACK

Size/SIZE: 1800 * 420 * 1800 mm

Features/FEATURE: First layer barbell plate insertion rack; Second layer dumbbell shelf; Third layer kettle bell shelf; Fourth layer medicinal ball/wall ball

Note: Color and size can be customized.



CF001 彩色全胶训练杠铃片

COLORED BUMPER PLATE

100% high-quality natural rubber, stainless steel rear pressure sleeve

Standard 450mm diameter, resistant to 8000 drops over 2 years

型号/ITEM	重量/WEIGHT	颜色/COLOR
CF001-05	5KG	
CF001-10	10KG	
CF001-15	15KG	
CF001-20	20KG	
CF001-25	25KG	



CF002 黑色全胶训练杠铃片

HIGH ELASTICITY BUMPER PLATE

100% high-quality natural rubber, stainless steel rear pressure sleeve

Standard 450mm diameter, resistant to 8000 drops over 2 years

型号/ITEM	重量/WEIGHT
CF002-05	5KG
CF002-10	10KG
CF002-15	15KG
CF002-20	20KG
CF002-25	25KG



CF005 彩色钢毂竞赛杠铃片

COMPETITION COLORED BUMPER PLATE

100% high-quality native rubber, fully electroplated steel hub

International IWF standard, 450MM diameter

型号/ITEM	重量/WEIGHT	颜色/COLOR
CF005-05	5KG	
CF005-10	10KG	
CF005-15	15KG	
CF005-20	20KG	
CF005-25	25KG	



CF012 黑色包胶三孔杠铃片

RUBBER COATED TRI-GRIP WEIGHT PLATE

Cast iron coated with stainless steel back press sleeve

Model/ITEM Weight/WEIGHT

CF012-2.5	2.5KG
CF012-05	5KG
CF012-10	10KG
CF012-15	15KG
CF012-20	20KG
CF012-25	25KG

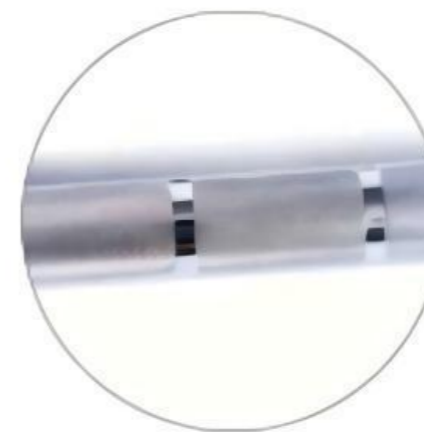

CF086

男士奥林匹克竞技举重杆
MEN'S COMPETITION OLYMPIC BAR

MEN'S COMPETITION OLYMPIC BAR
High quality spring steel, electroplated with hard chrome
8 * Needle roller bearing, double copper sleeve
Load capacity: 1500lbs
Length: 2200mm
Weight: 20kg
Grip diameter/diameter: 28mm

CF086W

女士奥林匹克竞技举重杆
WOMEN'S COMPETITION OLYMPIC BAR

WOMEN'S COMPETITION OLYMPIC BAR
High quality spring steel, electroplated with hard chrome
8 * Needle roller bearing, double copper sleeve
Load capacity: 1500lbs
Length: 2200mm
Weight: 20kg
Grip diameter/diameter: 28mm

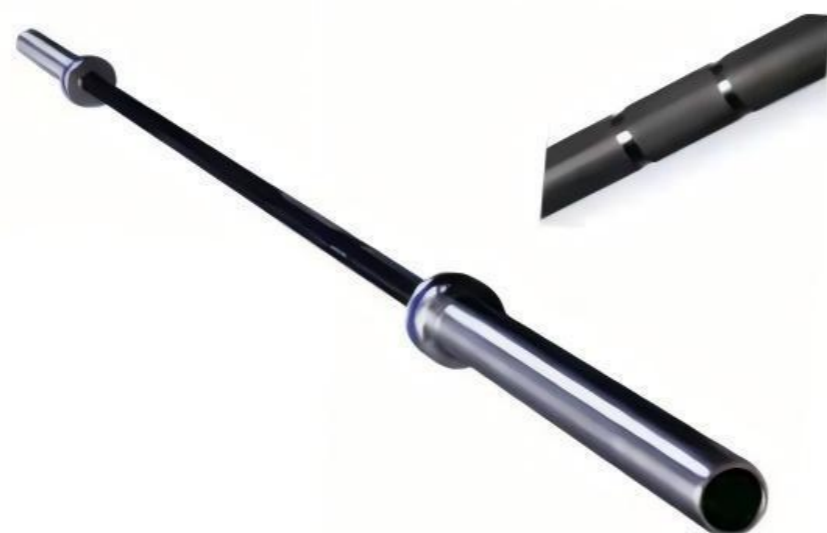

CF086BK

奥林匹克电镀黑铬举重杆
BLACK CHROME OLYMPIC WEIGHTLIFTING BAR

High quality spring steel, black chrome plated middle handle, hard chrome plated 8 * needle roller bearings on both sides of sleeves, double copper sleeves
Length: 2200mm (male)/2010mm (female)
Weight: 20kg (male)/15kg (female)
Load bearing capacity: 1500lbs/1000lbs
Grip diameter/center: 28mm/25mm



CF086
奥林匹克杠铃杆
OLYMPIC WEIGHTLIFTING BAR

High quality alloy steel, overall nickel plating, anti slip rolling pattern, 4 * needle roller bearings, double copper sleeves
Length: 2200mm (male) 2010mm (female)
Weight: 20kg (male) 115kg (female)
Load bearing capacity: 1000lb s/700lb s
Grip diameter I: 28mm/25mm



CF072W
铝制技术杆
TECHNICAL BAR

Made of high-quality aluminum alloy
Copper sleeve double bearing
Load bearing capacity: 500LBS
Length: 1800MM Weight: 7KG
Grip diameter/K: 25MM



CF072W
铝制技术杆
TECHNICAL BAR

Made of high-quality aluminum alloy
Copper sleeve double bearing
Load bearing capacity: 500LBS
Length: 1800MM Weight: 7KG
Grip diameter/K: 25MM

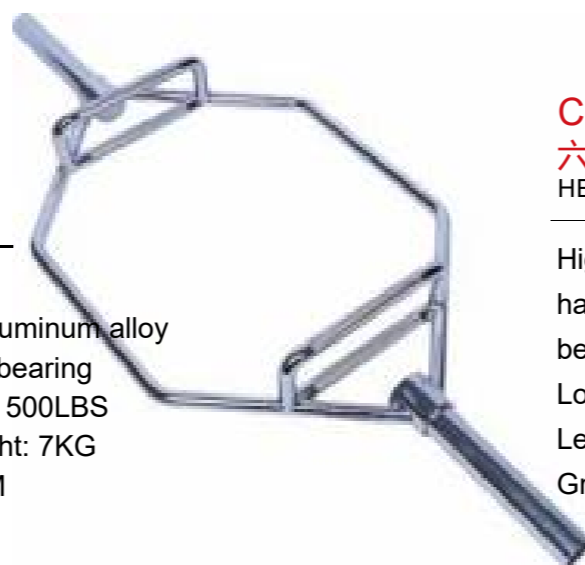

CF056
六角硬拉杠铃杆
HEXAGON SHRUG BAR

High quality alloy steel, electroplated hard chrome copper sleeve double bearings
Load bearing capacity: 700LBS
Length: 1400MIM Weight: 38KG
Grip diameter/K: 25MM

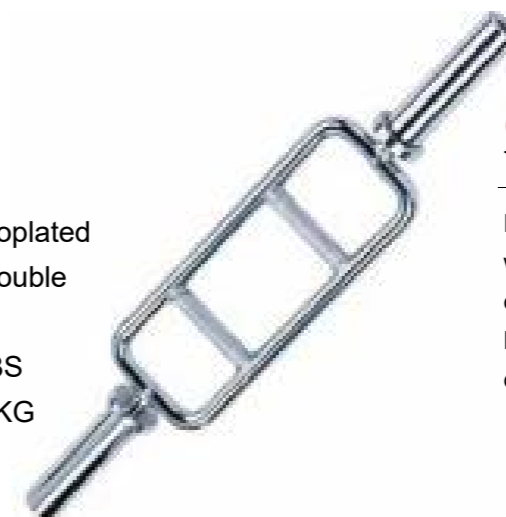

OB34C 方框器
TRICE P BAR

High quality alloy steel, electroplated with hard chrome standard lead hole diameter of 50mm
Length: 850mm Weight: 22KG Grip diameter: 25MM



CF009 磨砂喷塑竞技壶铃(带彩环)

CF009 COMPETITION KETTLEBELL

Stainless steel casting, black matte frosted sprayed surface
Colorful logo ring, convenient for distinguishing specifications and weights

Specifications: 4KG, 6KG, 8KG, 10KG, 12KG, 16KG, 36KG
(Note: 4/6kg ordinary kettle bell with colored ring)



CF009 彩色铸钢竞技壶铃

CF009 COLORED STEEL COMPETITION KETTLEBELL

CF training is essential, made of precision steel casting,
Beautiful color spray coating, each weight corresponds to a color, high-precision lathe polishing handle, excellent hand feel

重量 / WEIGHT	颜色 / COLOR	重量 / WEIGHT	颜色 / COLOR
4KG		16KG	
6KG		20KG	
8KG		24KG	
10KG		28KG	
12KG		32KG	



CF011 彩色浸塑壶铃
VINYL COATED KETTLE BELL

Refined cast iron, matte frosted handle, beautiful color dipping and coating
specifications: 4KG, 6KG, 8KG, 10KG, 12KG, 16KG, 20KG, 24KG, 28KG, 32KG, 36KG



CF008 黑色磨砂经典壶铃
IRON CAST KETTLE BELL

Ductile iron casting, high-end matte sprayed plastic surface, perfectly curved handle, good hand feel
Specifications: 4KG, 6KG, 8KG, 10KG, 12KG, 16KG, 20KG, 24KG, 28KG, 32KG, 36KG



CF015 六角包胶哑铃
HEX DUMBBELL

Export quality, made of high-quality native rubber, environmentally friendly and odorless, with a hard chrome plated handle in the middle, a rolling anti slip mechanic, wear-resistant and durable, and a hexagonal head design to ensure that it does not roll when placed
Specification: 2.5KG-50KG, every 2.5KG - jump



CF015 浸塑哑铃
HEX DUMBBELL

Refined cast iron, beautiful colored immersion molding, available in bone and hexagonal shapes
Specifications: 0.5KG, 1KG, 1.5KG, 2KG, 3KG



CF128 商用哑铃架
DUMBBELL RACK

Size/SIZE: 2200*650*850mm (24-bit), 78KG;
1600*650*850mm(16bit), 58KG;



CF140 商用壶铃架
KETTLE BELL RACK

Size/Dimensions: 1550*650*800mm (12位), 55KG;
1550*650*1200mm (18位), 75KG



CF040 墙球
WALL BALL

High quality nylon reinforced PVC leather, large color sheet, cross shaped sealing, wear-resistant and impact resistant 100% high-quality PP elastic cotton, filled purely by hand

Specifications: 3KG, 4KG, 5KG, 6KG, 7KG, 8KG, 9KG, 10KG, 12KG

重量/WEIGHT	颜色/COLOR	重量/WEIGHT	颜色/COLOR
3KG		8KG	
4KG		9KG	
5KG		10KG	
6KG		12KG	
7KG			

核心训练
Core Training



CF041 花式墙球
NEW WALL BALL

High end PU leather, small seal, resistant to impact; The new mosaic has a rounder spherical shape and a more stable center of gravity. 100% high-quality PP elastic cotton, filled purely by hand

Specifications: 4LB, 6LB, 8LB, 10LB, 12LB, 14LB, 16LB, 20LB, 25LB

重量/WEIGHT	颜色/COLOR	重量/WEIGHT	颜色/COLOR
4LB		14LB	
6LB		16LB	
8LB		20LB	
10LB		25LB	
12LB			



CF040P 专业墙球
PRO WALL BALL

High strength nylon fabric, resistant to falling, tearing, and abrasion;
100% high-quality PP elastic cotton, filled purely by hand

规格:	规格:
3KG/6.6LB	8KG/17.6LB
4KG/8.8LB	9KG/19.8LB
5KG/11.0LB	10KG/22.0LB
6KG/13.2LB	12KG/26.4LB
7KG/15.4LB	15KG/33.0LB







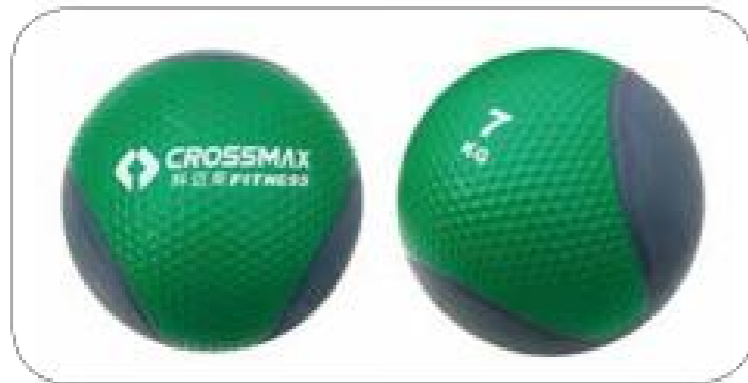



CF044 重力球
SLAM BALL

PVC material, anti slip pattern, not easy to slip,
filled with heavy sand specifications: 5LB, 10LB,
15LB-100LB (one jump per 5LB)



CF045 药球
MEDICINE BALL

Imported high-quality rubber, not easy to crack,
environmentally friendly and odorless
Specifications: 1kg, 2kg, 3kg, 4kg, 5kg, 6kg, 7kg, 10kg

重量/WEIGHT	颜色 / COLOR	重量/WEIGHT	颜色 / COLOR
1KG		5KG	
2KG		6KG	
3KG		7KG	
4KG		10KG	



CF046 双耳药球
MEDICINE BALL WITH HANDLE

Made of high-quality rubber, not easy to crack, environmentally friendly and odorless, ergonomic grip, colored sphere specifications: 3kg, 4kg, 5kg, 6kg

重量/WEIGHT	颜色 / COLOR	重量/WEIGHT	颜色 / COLOR
3KG		5KG	
4KG		6KG	



CF036 能量包
POWER BAG

High quality nylon reinforced PVC leather, colorful webbing, easy to choose specifications and weights, new color digital printing, beautiful appearance
Specifications: 5kg, 10kg, 15kg, 20kg, 25kg

重量/WEIGHT	颜色/COLOR	重量/WEIGHT	颜色/COLOR
5KG		20KG	
10KG		25KG	
15KG			



CF037 新款能量包
NEW POWER BAG

Made of high-quality nylon reinforced PVC leather; The new 6-way handle has more powerful functions. Colorful woven tape, easy to choose specifications and weights

Specifications: 5KG, 10KG, 15KG, 20KG, 25KG

重量/WEIGHT	颜色/COLOR	重量/WEIGHT	颜色/COLOR
5KG		20KG	
10KG		25KG	
15KG			





CF038 保加利亚包
BULGARIAN BAG

High quality nylon reinforced PVC leather, high-quality synthetic wool, pure handmade filling

Essential for core and lower back training

规格: 5KG, 8KG, 12KG, 17KG, 22KG

重量/WEIGHT	颜色/COLOR	重量/WEIGHT	颜色/COLOR
5KG		17KG	
8KG		22KG	
12KG			



CF052 花生健身球
PEANUT BALL

Specification 90 * 30cm (diameter)

Features: Made of high-quality thickened PVC, oil resistant and explosion-proof



CF064 手抓平衡板
BALANCE PLATE

Specification: 8 * 40cm (diameter)

Features: Made of high-quality engineering plastic, with a load-bearing capacity of 250KG, anti slip texture, and dual handle design.



CF048 波速球
BOSU BALL

Specification: 65cm (diameter)
Features: High quality thickened PVC, high-strength explosion-proof, Thickened plastic frame, equipped with foot pedal air cylinder



CF061 扳点按摩轴
FOAM ROLLER

Solid EVA material, non-toxic and odorless, massage design specifications: 330 * 140mm, 450 * 140mm



CF060 泡沫轴
FOAM ROLLER

High quality EVA foam, non-toxic and odorless, hexagonal floating point design specifications: 600 * 150mm, 900 * 150mm

CF050 健身球
GYM BALL

Specification: 65cm/75cm (diameter)
Features: Made of high-quality thickened PVC, oil resistant and explosion-proof



CF062 木质平衡板
WOOD BALANCE PLATE

Specification: 7.5 * 39cm (diameter)
Features: Reinforced multi-layer solid wood panel+anti slip veneer+spherical base, free rotation



CF095 飞力士健身棒
FLEX BAR

Material: Fiberglass, Rubber
Specification: 1600 * 23.5mm



CF089 普拉提圈
PILATE RING

Rubber fiberglass sheet, EVA foam cotton
Specification: Diameter 36cm, Weight: 450g

CF076 健身垫
GYM MAT

Adopting imported environmentally friendly TPE material, environmentally friendly and recyclable, Double sided anti slip pattern design, more convenient to use
Specification: 1830 * 610 * 6mm



CF093 健身按摩球
MASSAGE BALL

Natural rubber
Specification: Diameter 65mm, Weight 140g
Colors: Yellow, Red, Pink, Blue, Green, Black

CF07 平衡软踏
BALANCE PAD

High quality PU foam, good resilience, and softness
Specification: 40 * 50 * 6cm, 500g
Colors: Blue, Purple, Green, Black



CF091 齿轮按摩棒
MASSAGE BAR

Inner tube SS stainless steel+ABS roller PVC environmentally friendly handle
Specification: 6 wheels: total length 43cm (suitable for hands, legs, neck and other parts)
9 rounds: total length 52cm (suitable for all-around massage)

爆发力与阻力 Explosive & Resistance



CF065 乳胶阻力厚圈
RESISTANCE LOOP BANDS

Made of high-quality pure natural latex
Specifications: 15-35LB; 25-65LB; 35-85LB;
50-125LB; 65-175LB; 85-230LB;

拉力/TENSION	颜色/COLOR	拉力/TENSION	颜色/COLOR
15-35LB		50-125LB	
25-65LB		65-175LB	
35-85LB		85-230LB	



CF070 战绳
BATTLE ROPE

CF070 Battle Rope
BATTLE ROPE
Dimensions: 38mm * 15m, 50mm * 15m
Characteristics/FEATURE: Made of high-quality polyester; Immersion molded handle with optional integral cloth overprint logo (1 2cm)
Waving effect, captivating



CF072 爬绳
CLIMBING ROPE

CF072 Climbing Rope
CLIMBING ROPE
Size: 38mm * 6m
Characteristics/FEATURE: Manila hemp rope system;
Steel buckle;
Immersion plastic handle cover;



CF078 功能性训练轮胎
FUNCTIONAL TRAINING TYRE

Patent design, high-quality PVC leather full soft bag. Foam cushioning lining, simulating tread texture. Double sided 12 reinforced handles for pushing, pulling, and rolling, fully unleashing your athletic potential! Specifications: 80KG red, 60KG blue, 40KG green





CF 051 三合一软体跳箱
3 IN 1 SOFT PLYO METRIC BOX

Patent design, made of high-quality PVC leather, filled with high-density cushioning foam material, anti slip tread surface, more stable stepping
Specification: 50cm × 60cm × 75cm



CF055 软体跳箱套装
SOFT PLYO METRIC BOX SET

New patented design, beautiful color set
High quality nylon reinforced PVC leather
High density cushioning foam material filling
Specifications and colors: 6 "(purple), 12" (red), 18 "(green), 24" (blue)

爆发力与阻力
Explosive & Resistance



CF052 木质跳箱
WOODEN PLYO METRIC BOX

Multi layer solid wood, thickened board, mortise and tenon structure, easy to assemble
Size: 50cm (20 ") * 60cm (24") * 75cm (30 ")



CF054 防滑跳箱
ANTI SLIP PLYO BOX

Multi layer solid wood, with a non slip and leather like surface, safe, sturdy, and durable.
Size: 50cm (20 ") * 60cm (24") * 75cm (30 ")



CF053 钢制跳箱
STEEL PLYO METRIC BOX

Commercial carbon structural steel with fully bonded rubber anti slip layer on the surface
Specifications: 15cm, 30cm, 45cm, 60cm, 75cm;



CF059 腹肌垫
AB MAT

High quality PVC leather; High density foam material
Specification: 360x300 × 65mm



CF075 钢丝跳绳
SKIPPING ROPE

Size: Length 3m * Diameter 2.8mm
Features/FUTURE: Imported bearings; Patented design



CF090 举重腰带
WEIGHTLIFTING BELT

Color/COLOR: Brown; Black;
Features/FEATURE: Made of top layer cowhide; Steel buckle



CF076 铝合金卡扣
ALUMINIUM BARBELL COLLAR



CF074 杠铃卡头
BARBELL COLLAR



CF071 防滑镁粉盒架
MAGNESIUM POWDER RACK



高台拳击台
BOXING RING

Specification/SIZE: 4m * 40cm; 5m*5m*50cm; 6m*6m*60cm; 7m*7m*1m, Sizes can be customized
Features/FUTURE: High quality steel frame combination; Surface spraying treatment; Multi layer solid wood panel for countertop; Thickened canvas cover sheet; A complete set of luxurious soft bags, with customizable countertop height.



落地拳击台
FLOOR BOXING RING

Specification/SIZE: 4m * 4m; 4.5m*4.5m; 5m*5m; 6m*6m;
Customizable Size Features/FEATURE: New floor standing design, high-quality steel wire rope soft bag, thickened canvas cover



CF1035 拳击手套
BOXING GLOVES

Specifications: 10oz, 12oz
Features/FEATURE: Made of thickened microfiber leather; High density elastic foam filling, Hand shape conforms to ergonomics, comfortable to wear;



高台八角笼
MMA CAGE

Specification/SIZE: 4m * 40cm; 5m*5m*50cm; 6m*6m*60cm; 7m*7m*1m, Sizes can be customized
Features: High strength hot-rolled cage mesh, surface impregnation, deformation resistance, no cracking, thick steel structure frame, fully soft package, PVC anti slip cover, thick cushion pad.



落地八角笼
FLOOR MMA CAGE

Specification/SIZE: 4m * 4m; 4.5m*4.5m; 5m*5m; 6m*6m,
Customizable size features/FEATURE: High strength hot-rolled cage mesh, surface impregnation, deformation resistance, no cracking.



CF1038E 弧形拳靶
CURVED PUNCH MITTS

Specification: 23cm * 32cm * 6cm
Features/FUTURE: Thickened microfiber; High density elastic foam filling



MMA格斗卷垫
ROLL MAT

Specification/Size: Width 1500mm, Thickness 30/40/50mm,
Length 3-15m
Features: Thick anti slip PVC leather, environmentally
friendly high buffering XPE foam layer, seamless
connection with Velcro, beautiful and overall good!

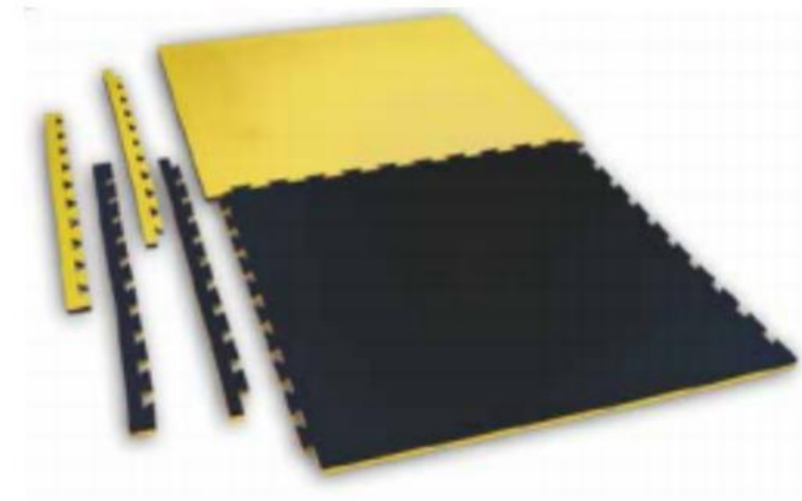

EVA拼接格斗垫
EVA MAT

Specification: 1000 * 1000 * 25/30/40mm;
Features: Environmentally friendly EVA foam, non-toxic,
odorless, letter mouth;



CF039 MMA格斗沙袋/假人
HEAVY BAG & DUMMY

Specification: 180x40cm 60kg; 150x40cm 45kg;
Features/FEATURE: Made of thickened PVC leather,
100% new fabric factory scrap, pure manual filling;



CF2215新款弧形脚靶
PUNCH PAD

Specification: 40 * 20 * 13cm
Features/FEATURE: High quality thickened microfiber
leather; High density elastic foam filling; Strengthen the
handle

Mats G Flooring 地面材料

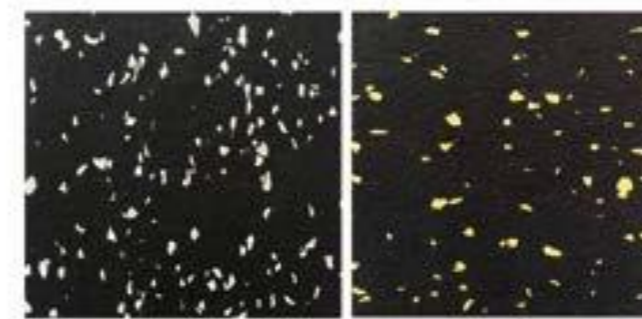
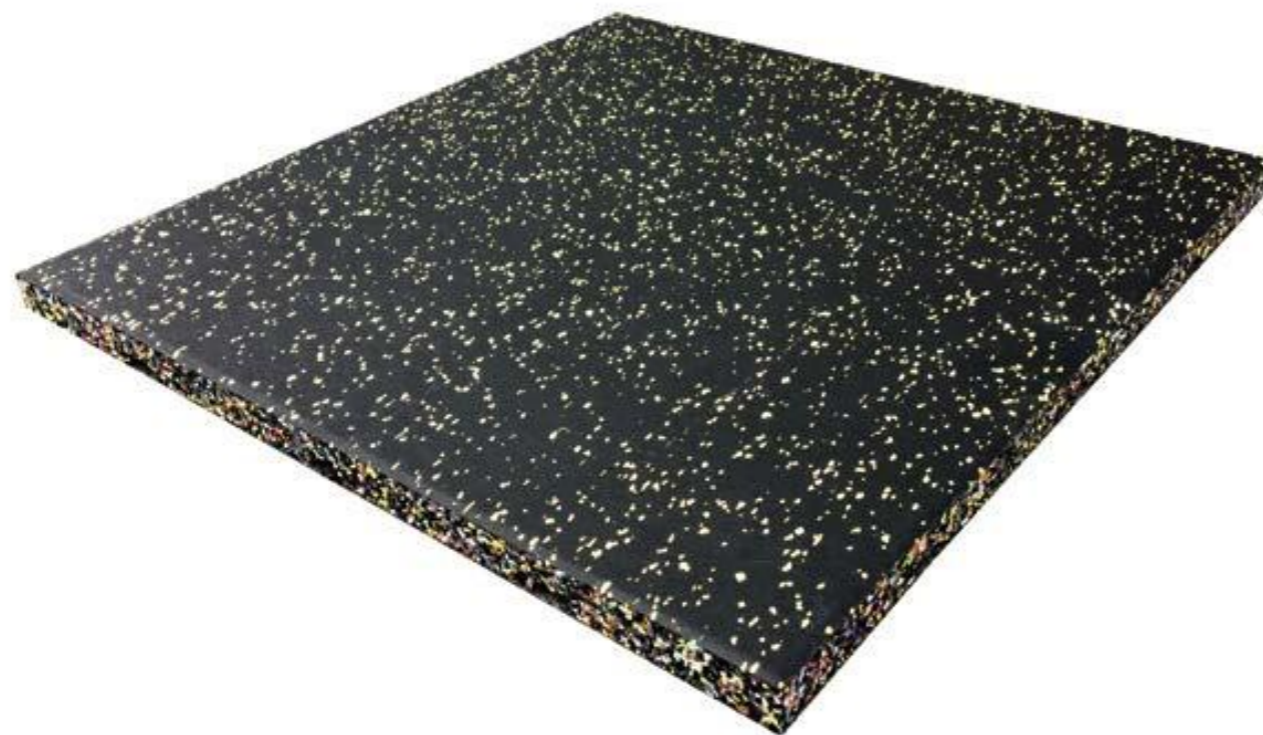

白

黄

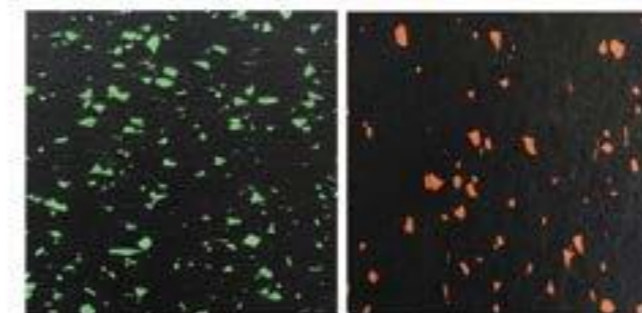

绿

红

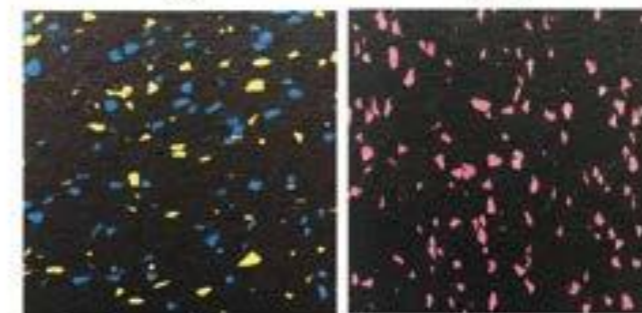

黄蓝

玫红

CF211 满天星复合减震地胶

GYM RUBBER MAT

Made of high-quality and environmentally friendly rubber, meeting export quality standards, environmentally friendly and odorless. Wear resistance, aging resistance, good tear resistance, good impact resistance, neat edges, and small paving gaps.

Specification/SIZE: 1000x1000x15mm; 500x500x15mm;
1000x1000x20mm; 500x500x20mm;
1000x1000x25mm; 500x500x25mm;
1000x1000x30mm; 500x500x30mm;

Color: Black background+colored EPDM particles (gray, yellow, blue, orange, green, rose red, etc.)



CF212 泡面复合锁扣减震地胶
GYM RUBBER MAT

High quality foam composite floor glue, environmentally friendly, no odor, wear-resistant and anti-aging,
Good tear resistance, excellent impact buffering performance, and small gaps in the connection and paving of the lock buckle. Specification: 1000x1000x10mm;
500x500x10mm;
1000x1000x15mm; 500x500x15mm;
1000x1000x20mm; 500x500x20mm;
Color: Black background+colored EPDM particles (gray, yellow, blue, orange, green, rose red, etc.)

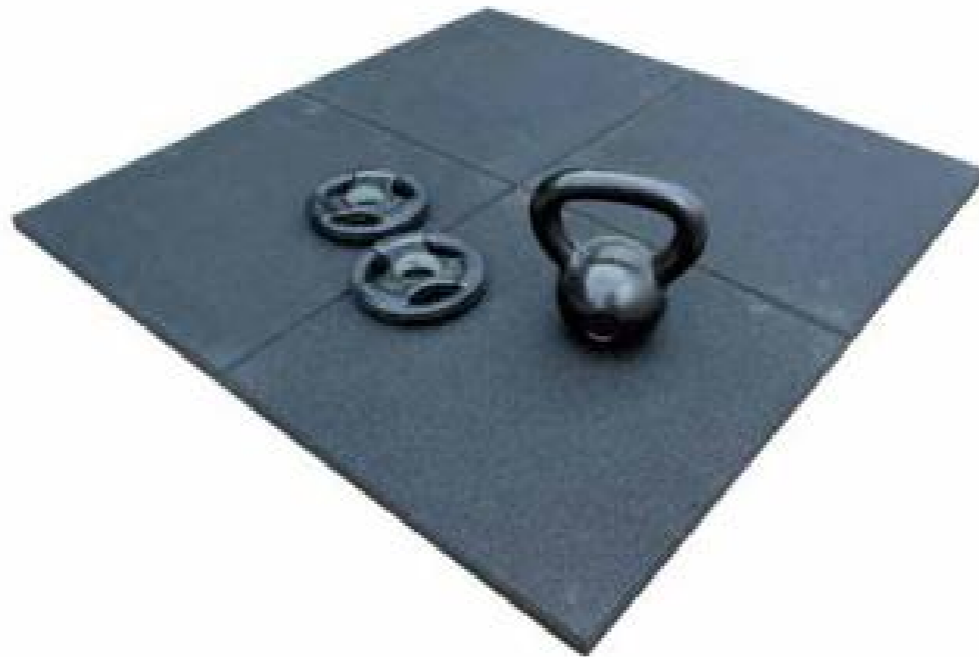

CF210 纯橡胶地垫
GYM RUBBER MAT

Made of high-quality pure rubber fine particles, meeting export quality standards, environmentally friendly and odorless. Wear resistant without shedding debris, tear resistant, good toughness, and excellent impact buffering performance.

Specification: 1000x1000x15mm; 500x500x15mm;
1000x1000x20mm; 500x500x20mm;
1000x1000x25mm; 500x500x30mm;
1000x1000x30mm; 500x500x50mm;

Color: Pure black, black background+colored EPDM particles (gray, yellow, blue, orange, green, rose red, etc.)



CF230 EPDM 星光橡胶卷材
GYM RUBBER ROLLS

Made of high-quality pure rubber, meeting export quality standards, environmentally friendly and odorless.

Excellent wear resistance, good seismic buffering, noise reduction, corrosion resistance, moisture and mold resistance

Thickness: 4mm/6mm/8mm/10mm,

Width Width: 1m Length: 5m, 10m, 15m-20m,

Color COLOR: Pure black, black background+colored EPDM particles (gray, yellow, blue, orange, green, rose red, etc.)



CF201W 举重木板
WEIGHTLIFTING PLATFORM PLANK

Specification/SIZE: 2000X1000X20/25MM,

Material: Multi layer solid wood bamboo board, steam high-temperature pressing, impact resistance, not easily deformed or warped

CF360 功能地胶
FUNCTIONAL ZONE

Product Features Features:

The latest international Function a zone functional case library. Specially designed for private teaching, functional training, and group course development.

Beautiful and wear-resistant, sound-absorbing and shock-absorbing, anti slip and weight resistant, suitable for placing weight training equipment.

Full UV coating, non fading, anti pollution and easy to clean.

Width: 1500mm,

Thickness: 2.0/3.0/4.5/6.0/8.0mm

Multi layer composite structure: surface UV coating anti fouling and wear-resistant, 100% PVC wear-resistant transparent layer, imported ink printing layer, thickened 60 thread PVC wear-resistant layer, high-strength fiberglass grid stable layer, PVC foam buffer base layer, surface crystal sand anti slip particles,

Note: Provide on-site measurement, design drawings, customized production, and paving (some projects are charged)

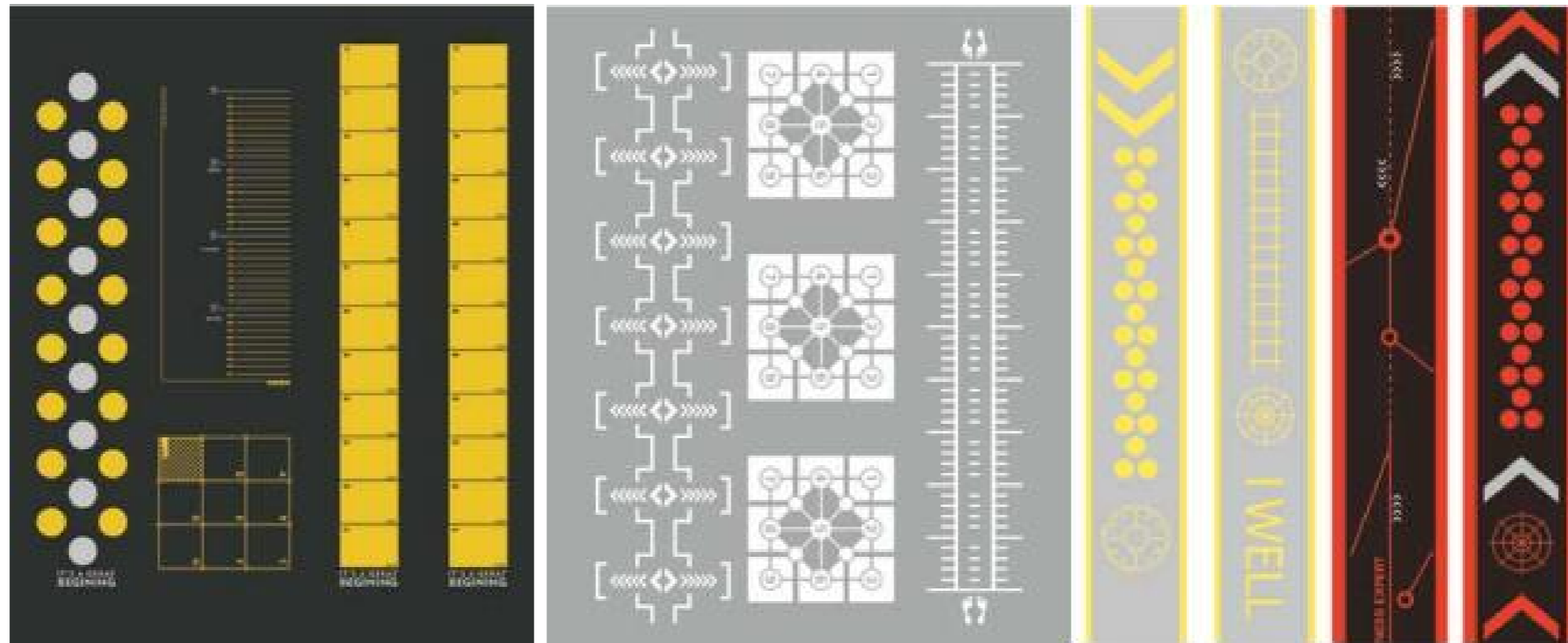
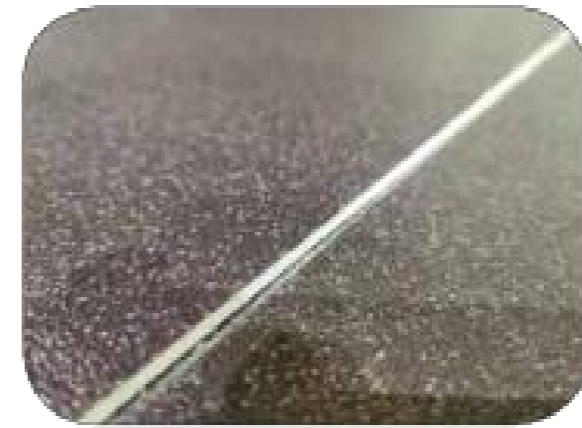

CF366 加厚耐磨层 PVC运动地胶
PVC SPORT FLOOR

Width 2m,
Thickness: 4.0mm
Length: 10/15/20m, any length
Features: PVC foam substrate with excellent motion buffering performance, Comfortable foot feel, 60 thread thick PVC wear-resistant layer, pressure resistant and wear-resistant, fully UV plated anti pollution.

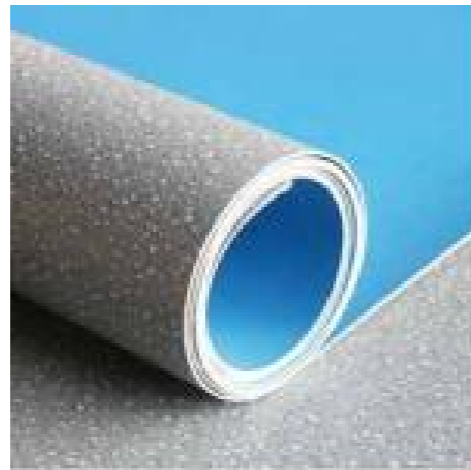

CF362 密实底 PVC商用卷材
COMMERCIAL PVC FLOOR

Width: 2m,
Thickness: 2.0mm
Length: 10/15/20m, any length
Features: Dense substrate, resistant to compression and deformation, thickened PVC wear-resistant layer, anti slip texture, resistant to compression and wear,

CF365 PVC 复合运动地板
PVC SPORT FLOOR

Specification: Width 1500/1800mm, Thickness 3.5/4.5/6.0/8.0mm
Material: High quality PVC composite sports floor,
Texture: Gemstone pattern/Wood pattern/Ball skin pattern/Lychee pattern/Steel plate pattern
Features/FUTURE:
Good buffering elasticity, anti slip and wear-resistant, noise reduction, moisture-proof and mildew proof, non flammable, widely applicable to aerobic areas, equipment areas, exercise rooms, dance studios, badminton, table tennis, basketball, tennis, volleyball, kindergartens, etc





CF365 PVC 复合运动地板

PVC SPORT FLOOR

Specification: Width 1500/1800mm, Thickness 3.5/4.5/6.0/8.0mm Material: High quality PVC composite sports floor,

Texture: Gemstone pattern/Wood pattern/Ball skin pattern/Lychee pattern/Steel plate pattern

Features/FUTURE:

Good buffering elasticity, anti slip and wear-resistant, noise reduction, moisture-proof and mildew proof, non flammable, widely applicable to aerobic areas, equipment areas, exercise rooms, dance studios, badminton, table tennis, basketball, tennis, volleyball, kindergartens, etc



CF240 跑道草坪

CUSTOMIZED RUNWAY TURF

Specifications: 4x12m, 6x12m, 8x15m (customizable size)

Recommendation: Grass height 25mm, PE+PP material, emerald green curved silk, A high-density sports lawn with a cluster density of 19800 per square meter.

Features/FUTURE:

High quality sports lawn+real white grass production, factory customized straight hair, ready to use upon receiving and laying, compared to on-site cutting and splicing lawns: shorter construction period, less prone to cracking, and no shedding of grass fibers,

The most important thing is that there is no on-site adhesive or pungent odor, which is environmentally friendly and safe.

Note: Provide on-site measurement, design drawings, customized production, and paving (some projects are charged)



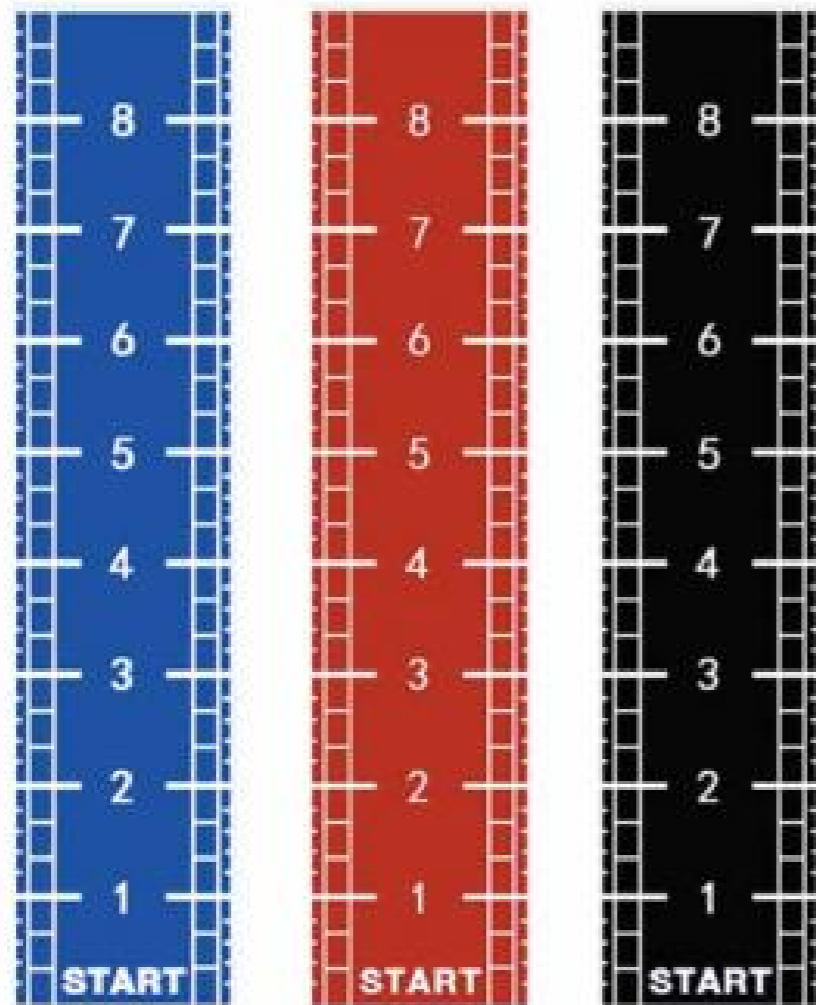

CF241 刻度草坪
SCALE LINED TURF

Specifications: 2x12m, 2x15m, 2x20m (sizes can be customized)
 Recommendation: A high-density specialized sports lawn with a grass height of 16mm, PE+PP material, and a cluster density of 69800/square meter. Red, blue, yellow, green, and black colors are available as shown in the picture:
 Features: 69800 ultra-high density, full warp support, strong elasticity, comfortable foot feel, and excellent athletic performance.



CF242 功能图案草坪
FUNCTIONAL TRAINING TURF

Specifications: 6x8m, 6x12m, 8x12m (sizes can be customized)

Recommended: A high-density specialized sports lawn with a grass height of 16mm, PE+PP material, and a cluster density of 69800/square meter.

Provide rich customization of functional training patterns, venue logos, brand logo, etc





CF245 缓冲复合草坪
FOAM COMPOSITE D TURF

Specifications: 4x8m, 6x12m, 2x12m, 2x15m (sizes can be customized)

Material: 12mm XPE foam buffer layer, using hot melt composite technology, combined with the back adhesive of the lawn base, sturdy and non delamination, excellent shock absorption and buffering performance, suitable for high-intensity running and jumping sports and children's sports protection.

